

TOOLING SOLUTIONS FOR

ADVANCED HIGH STRENGTH STEELS



© UDDEHOLMS AB

No part of this publication may be reproduced or transmitted for commercial purposes without permission of the copyright holder.

This information is based on our present state of knowledge and is intended to provide general notes on our products and their uses. It should not therefore be construed as a warranty of specific properties of the products described or a warranty for fitness for a particular purpose.

Classified according to EU Directive 1999/45/EC
For further information see our "Material Safety Data Sheets".

Edition: 2, 10.2016



Selecting a tool steel supplier is a key decision for all parties, including the tool maker, the tool user and the end user. Thanks to superior material properties, Uddeholm's customers get reliable tools and components. Our products are always state-of-the-art. Consequently, we have built a reputation as the most innovative tool steel producer in the world.

Uddeholm produce and deliver high quality Swedish tool steel to more than 100,000 customers in over 100 countries.

Wherever you are in the manufacturing chain, trust Uddeholm to be your number one partner and tool steel provider for optimal tooling and production economy.

CONTENTS

Introduction	5
Uddeholm's offer to the automotive industry	5
Sheet steels and tool steels	6
– Advanced high strength steels	6
– Tool steels	7
Tool steel selection guidelines	9
– Overview	9
– Forming tool operations	11
– Cutting tool operations	16
– Application examples	30
Lubrication	31
– Forming tool operations	
– Cutting tool operations	
Tooling economy	32
Technical support	33
– Experts to help you	
– Advanced resource for analysis	
– Courses and seminars	
– Technical information	



B-Pillar to a car.

INTRODUCTION

Using advanced high strength steels (AHSS) can provide organizations with many advantages. However, with the increasing use of advanced high strength steel in new product designs, higher demands are also placed on tool steels used in forming and blanking/punching operations. The purpose of this publication is to provide selection guidelines that enable design engineers and material experts to find the best tooling solution for forming and blanking/punching advanced high strength steels with the following steel types:

- micro alloyed steels
- bainitic steels
- dual phase steels
- complex phase steels
- roll forming steels
- martensitic steels

From an environmental standpoint, advanced high strength steels can significantly reduce weight in producing a detail, allow for smaller amounts of raw material to be used and consume less energy. At the same time, less energy is needed to transport the steel and the steel itself is also totally renewable.

There are also applications where advanced high strength steel makes it possible to exclude tempering furnaces from the manufacturing process, and consequently the environmental hazards involved.

In the automotive industry, lower emission levels can be achieved by reducing vehicle weight. On the other hand, the ever increasing demand for safety in cars necessitates higher strength materials to be used in critical safety elements in the car body. There are also many industrial products where reduced weight and increase product durability can be achieved by utilizing advanced high strength steel in their designs.

The use of advanced high strength steel may require higher force to cut and form the sheet steel. Therefore, the need for higher hardness and ductility in the tool steel becomes obvious. The present situation and future development in advanced high strength steel forces the desired tool steel properties to develop even further to match the requirements.

The guidelines presented here reflect the latest results and best working practices developed by Uddeholm at the time of release of this publication. The information is based on comprehensive research and testing performed over a long period, and in close cooperation with many of our most advanced customers.

The main goal for Uddeholm is to provide solid information to enable customers to select the best combination of advanced high strength steel and tool steel for any given product design.

UDDEHOLM'S OFFER TO THE AUTOMOTIVE INDUSTRY

The world's automotive industry is one of Uddeholm's most important customer groups.

Uddeholm's package for the automotive industry is created to meet the need of the automotive OEM's for shorter delivery times. The package focuses on optimal total economy, less downtime in production and shorter lead times, within the following areas.

- In cold work, a new generation of presswork tool steels has been developed.
- Within the hot work segment Uddeholm especially focus on long run die casting production, hot forging and hot stamping.
- In plastic moulding, as the leading developer of high quality plastic mould steels, the tool life and performance can be maximized and great savings in productivity and total tooling cost can be achieved.

Uddeholm is a global company. In our global offer to OEM's we focus on products and services on a worldwide basis. Our message for the OEM's is that we have the best products and we can support them both technically and commercially wherever they decide to build their tools or produce their products.

This means that we don't sell just a piece of steel, we sell a full package including services like heat treatment, machining and welding.

SHEET STEELS AND TOOL STEELS

ADVANCED HIGH STRENGTH STEELS

Advanced high strength steels can be obtained as hot rolled, cold reduced, hot-dip galvanized and electro galvanized products. For example, Advanced High Strength Steels are used in:

- safety components in cars
- trailers
- tippers
- seat components
- containers
- cranes
- trains
- various tube applications such as furniture, bicycles and baby carriages

There are several parameters that decide which of the Advanced High Strength Steel types to be used. The most important parameters are derived from the geometrical form of the component and the selection of forming and blanking method.

MICRO ALLOYED STEELS

The micro alloyed cold-forming steels derive their high strength from the addition of very small quantities of micro-alloying elements such as niobium and titanium. These steel grades are designated according to the lowest guaranteed yield strength. The difference between their yield strength and tensile strength is small. These steel grades have excellent bendability, pressforming

and flanging properties in relation to their yield strength. The weldability is also good.

BAINITIC STEELS

The bainitic steels are available as hot rolled material. These types of steels are thermo-mechanical rolled. The figures in the steel designation specify the minimum yield strength.

DUAL PHASE STEELS

Dual Phase, cold-forming steel has a microstructure that consists of two phases, ferrite and martensite. Ferrite is soft and contributes to good formability. Martensite is hard and contributes to the strength of the material. The strength increases with increasing proportion of the hard martensite phase. Depending on the application, dual phase steels in different yield ratio (YS /TS) can be achieved. The figures in the steel designation specify the minimum tensile strength. Dual phase steels are easy to cut and form and can be welded with conventional welding methods.

COMPLEX PHASE STEELS

The microstructure of complex phase steels contains small amounts of martensite, retained austenite and pearlite within the ferrite/bainite matrix. CP steels are characterized by a high yield strength, moderate strain hardening and good ability for bending and flanging. The figures in the steel designation specify the minimum tensile strength. The complex phase steels are available as hot-dip galvanized steel grades.

NOMENCLATURE OF ADVANCED HIGH STRENGTH STEELS

ROLLING TYPE	MECHANICAL PROPERTIES		STEEL TYPE	COATING TYPE
CR = Cold rolled HR = Hot rolled	xxxY xxx = Rp0.2 min.	xxxT xxx = Rm, min.	MC = Small grain size low alloyed LA = Low or micro-alloyed FB = Ferritic bainitic DP = Dual phase CP = Complex phase MS = Martensitic	EG = Electrogalvanized zinc coating ZN = Electrogalvanized zinc-nickel coating GI = Hot dip zinc coating GA = Hot dip zinc-iron coating AS = Hot dip aluminium-silicon coating

Table 1. These designations are used in the following text to characterize the high strength work materials.

Examples: CR780Y-CP = cold rolled steel with minimum yield strength of 780 MPa of complex phase type
HR1180T-MS = hot rolled steel with minimum tensile strength of 1180 MPa of martensitic type

ROLL FORMING STEELS

The roll forming steels are available as cold reduced and hot-dip galvanised products. This group of steel is primarily designed for applications where roll forming is used as a forming method. The roll forming steels are characterized by high yield ratio (YS /TS), high internal cleanliness and a microstructure with homogeneous hardness distribution. These characteristics minimize the risk for twisting and bending of the profile, and make it possible to roll form into narrow radii.

MARTENSITIC STEELS

Martensitic steels contain 100% martensite. Martensitic steels characterize a material in very high yield and tensile strength. For hot rolled material, the figures in the steel designation specify the minimum yield strength, and for cold rolled material, the minimum tensile strength.

TOOL STEELS

CHARACTERISTICS FOR FORMING AND CUTTING OPERATIONS

A typical request for tools used in cold work applications is a high hardness. The reason is that the work materials to be formed are often hard. A high tool hardness is therefore necessary to prevent plastic deformation and/or heavy tool wear.

A negative consequence of high hardness level is that the tool material becomes more brittle.

Tool steel for cold work applications need high wear resistance, sufficient compressible strength and toughness/ductility or, more specifically:

- high wear resistance to increase tool life and to reduce the need for production stoppages for tool maintenance
- sufficient compressible strength to avoid plastic deformation of the active tool surfaces
- sufficient toughness/ductility to avoid premature tool breakage and chipping

High wear resistance is not just a question of hardness. Typically, tool steel grades for cold work applications also contain hard carbides, giving an extra contribution to the wear resistance. These carbides are chemical compounds of carbon and carbide forming elements such as chromium, vanadium, molybdenum or tungsten.

Generally, the more frequent, larger and harder the carbides are, the better wear resistance is achieved in the tool. There are, however, conflicting consequences as high hardness makes the material sensitive to notches. This may lead to large carbides acting as crack initiators in a fatigue process. The majority of broken tools fail due to fatigue cracking.

Fatigue cracking occurs when the material is exposed to alternating/pulsating loads and can be divided in a crack initiation stage and a crack propagation stage. Crack initiation normally takes place at notches, which magnify the stress locally by stress concentration. The higher the hardness the more efficient the stress concentration becomes. Typical for a high hardness is also that as soon as a crack is initiated, the time to a total tool breakage is very short.

The difficulty with cold work applications in general, especially when blanking hard work materials, is that you must minimize crack initiating defects. This must be done while maintaining wear resistance which demands high hardness and hard particles in the steel matrix.

Crack initiating defects such as notches are not necessarily due to carbides. Large slag inclusions, defects in the tool surface or sharp corners in combination with high hardness may also act as sites for crack initiation at fatigue loading. For this reason, the cleanliness of the metallurgical process and the surface finish of the tool or the tool design will strongly influence tool performance. In Table 2 on page 8, the Uddeholm product range of tool steels suitable for advanced high strength steel is shown.

UDDEHOLM PRODUCT RANGE OF TOOL STEELS SUITABLE FOR ADVANCED HIGH STRENGTH STEELS

UDDEHOLM STEEL GRADE	TYPE OF METALLURGY	AISI/W.-NR.	CHEMICAL COMPOSITION (WEIGHT %)						
			C	Si	Mn	Cr	Mo	W	V
Sleipner	Conventional	–	0.90	0.9	0.5	7.8	2.5	–	0.5
Sverker 21	Conventional	D2 / 1.2379	1.55	0.3	0.4	11.3	0.8	–	0.8
Calmax	Conventional	– / 1.2358	0.60	0.35	0.8	4.5	0.5	–	0.2
Unimax	Electro slag remelting	–	0.50	0.2	0.5	5.0	2.3	–	0.5
Caldie	Electro slag remelting	–	0.70	0.2	0.5	5.0	2.3	–	0.5
Vanadis 4 Extra SuperClean	Powder metallurgy	–	1.40	0.4	0.4	4.7	3.5	–	3.7
Vanadis 8 SuperClean	Powder metallurgy	–	2.30	0.4	0.4	4.8	3.6	–	8.0
Vancron 40 SuperClean	Powder metallurgy	–	3.00 ¹⁾	0.5	0.4	4.5	3.2	3.7	8.5

¹⁾ % (C + N)

Table 2.

CONVENTIONAL METALLURGY

When manufacturing conventional high alloyed tool steels, the use of large ingots means that the steel melt will solidify slowly. This results in coarse carbide networks being developed. These carbide networks will cause coarse carbide streaks in the tool material after rolling or forging. These carbide streaks are positive for the wear resistance but have a negative influence on the mechanical strength of the tool material, especially at fatigue loading.

To reduce the negative influence of carbide networks the chemical composition has to be balanced to reduce or even avoid coarse carbide networks, while compensating for the loss of wear resistance by the increased matrix hardness.

An alternative way is to develop a metallurgical process which gives small and well distributed carbides that have less negative impact on fatigue strength but still protect the tool from wear.

Uddeholm has two metallurgical processes that improve the situation compared with conventional metallurgy. These are:

- Electro Slag Remelting (ESR), Figure 1
- Powder Metallurgy (PM), Figure 2

ELECTRO SLAG REMELTING METALLURGY

Electro slag remelting is a well-known metallurgy process in which a conventionally produced ingot is successively remelted in a pro-with a small steel melt. This smaller steel melt solidifies much faster than a larger steel melt, giving less time for

carbide growth after solidifying. The remelting process gives steel with improved homogeneity and less overall carbide sizes. The process also includes a slag filter, which improves the steel cleanliness.

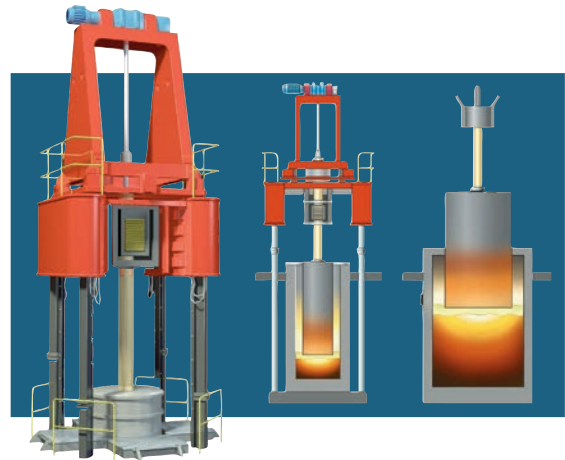

Figure 1. Electro slag remelting (ESR) process.

POWDER METALLURGY

In the powder metallurgy process nitrogen gas is used to atomize the melted steel into small droplets, or grains. Each of these small grains solidifies quickly and there is little time for carbides to grow. These powder grains are then compacted to an ingot in a hot isostatic press at high temperature and pressure. The ingot is then rolled or forged to steel bars by conventional methods.

The resulting structure is completely homogeneous steel with evenly distributed small carbides, harmless as sites for crack initiation but still protecting the tool from wear.

Large slag inclusions can take the role as sites for crack initiation instead. Therefore, the powder

metallurgical process has been further developed in stages to improve the cleanliness of the steel. Powder steel from Uddeholm today is of the third generation. They are considered the cleanest powder metallurgy tool steels on the market.

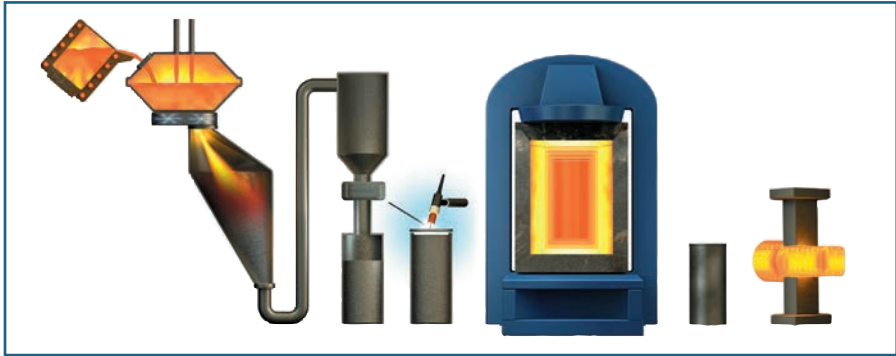

Figure 2. Powder metallurgy (PM) process.

TOOL STEEL SELECTION GUIDELINES

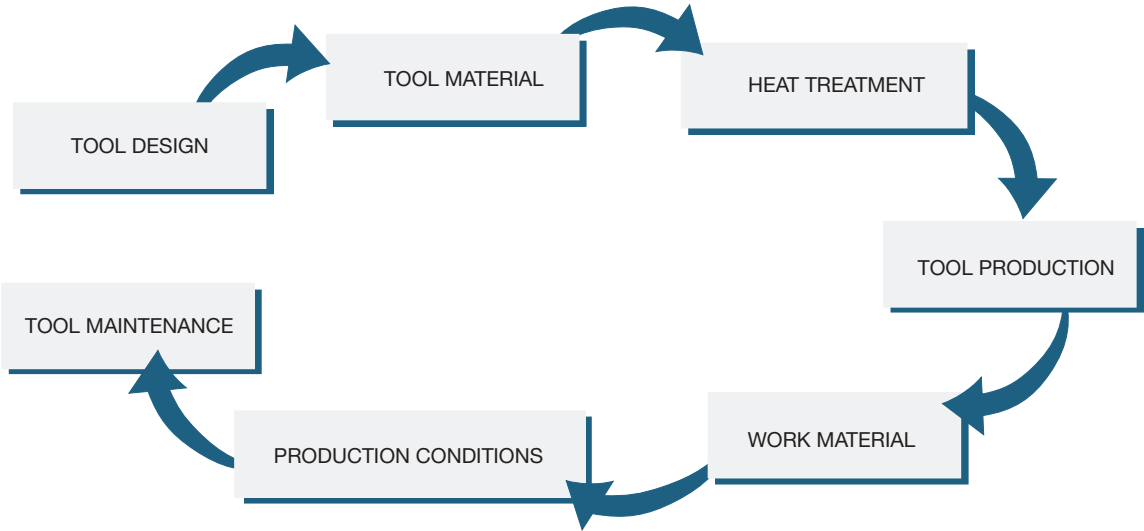

Figure 3. Process steps from tool design to tool maintenance

OVERVIEW

In forming and cutting operations of sheet metal parts, as in all industrial manufacturing operations, it is important that the production runs without trouble. The chain from tool design to tool maintenance includes many different steps as shown in Figure 3.

To achieve good productivity and tooling economy it is essential that the right tool steel is selected and that all steps in the chain are carried out correctly.

To select the right tool steel for the application in question it is essential to identify the mechanisms which can lead to premature tool failures. In forming and cutting operations there are five principal failure mechanisms.

- Wear, abrasive or adhesive, related to the operation, the work material and the friction forces due to sliding contact between the tool and the work material.
- Plastic deformation, which appears when the operating stress level exceeds the compressive yield strength (hardness) of the tool material.
- Chipping, which is a result of high working stresses compared to the fatigue strength of the tool material.
- Total cracking, which is a result of high working stresses compared to the fracture toughness of the tool material.
- Galling (pick-up), which is a result of heavy friction forces due to the sliding contact and the adhesive nature of the work material. The galling mechanism is closely related to adhesive wear.

Plastic deformation, chipping and total cracking are spontaneous failures and result in severe and costly production disturbances. They must be avoided if possible. Wear and galling are more predictable and can, to a certain extent, be handled by tool maintenance schedules. A consequence of this is that it may be worthwhile to allow more tool wear rather than to run into situations with chipping and cracking.

The yield strength of the steel sheet has to be exceeded during forming and the shear rupture strength has to be exceeded during cutting. This means that in forming and cutting operations in advanced high strength steel sheets, the forces needed to perform the operation are higher than for softer sheets of the same thickness.

In the same way, the demands on wear resistance and mechanical strength of the tool material increase. The cutting operation is more sensitive since it requires a combination of high wear resistance, high galling resistance, high compressive strength, high chipping and total cracking

Wear, abrasive or adhesive

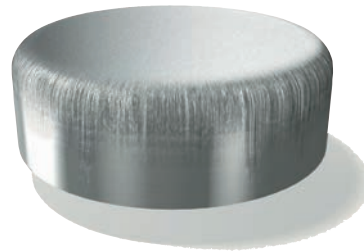

Chipping

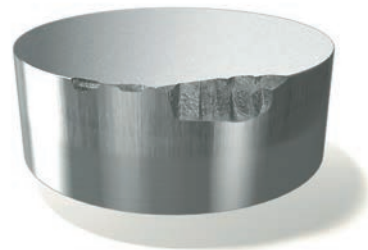

Galling

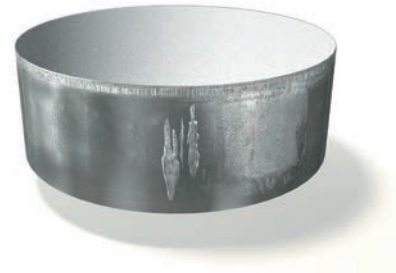

resistance. On the other hand, the forming operation is more concerned with high wear and galling resistance and compressive strength.

Furthermore, the die clearance has to be changed. Shock waves may appear in the tool and the burr formation is different when blanking/punching sheets with Rm 1200–1400 MPa. See also Figure 15, page 20. Forming of advanced high strength steels also means a reduced formability, increased spring back and increased wrinkling tendencies.

The tooling environment becomes accordingly more complex and demanding with these new advanced high strength steel materials.

Forming and cutting operations in sheets of higher strength steel grades may lead to rapid deterioration of the tool surface, or cracking of the tool if inadequate tool steels are selected. This means the selection of tool steel and coating processes for forming and cutting operations in advanced high strength steel should not be based on what was done in the past with softer mild

steel sheet materials. Instead, one should use the latest technical innovations to optimize the production economy.

In the table below a relative comparison of the resistance to different types of tool failure mechanisms for the Uddeholm product range intended for advanced high strength steel applications is shown.

RELATIVE COMPARISON OF THE RESISTANCE TO DIFFERENT TYPES OF FAILURE MECHANISMS

UDDEHOLM STEEL GRADE	AISI	Hardness/ Resistance to plastic deformation	Wear resistance		Resistance to fatigue crack initiation	
			Abrasive wear	Adhesive wear	Ductility/ Resistance to chipping	Toughness/ Resistance to gross cracking
Calmax	-	██████	████	██████	████████	██████████
Caldie	-	██████	████	██████	████████	██████████
Sleipner	-	██████	████	██████	████	████████
Sverker 21	D2	██████	██████	████	████	████████
Unimax	-	██████	████	██████	██████████	██████████
Vanadis 4 Extra*	-	██████	██████	██████	████████	████████
Vanadis 8*	-	██████	██████	██████	████	████████
Vancron 40*	-	██████	██████	██████	████	████████

* Uddeholm PM SuperClean tool steel

Table 3.

FORMING TOOL OPERATIONS

GENERAL

Advanced high strength steels have good formability and can be formed in the traditional way, despite their high strength.

The somewhat poorer formability compared to mild steels can almost always be compensated for by modifying the design of the component or the forming process. Larger radii in the tool that help the material flow in combination with optimized blank shape are factors that can make the forming of advanced high strength steels easier. A good example when these design issues have been taken into account is shown in Figure 4. Here it was possible to stamp a quite complex part in CR1200T-MS even though in general terms the formability of advanced high strength steel is lower compared with mild steel, see Figure 5.

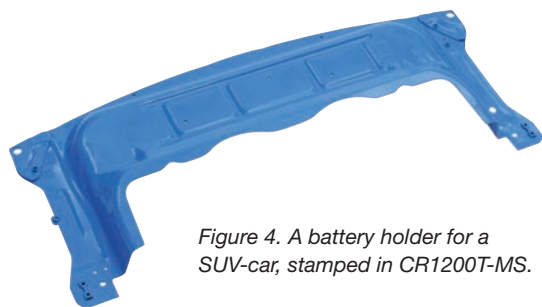

Figure 4. A battery holder for a SUV-car, stamped in CR1200T-MS.

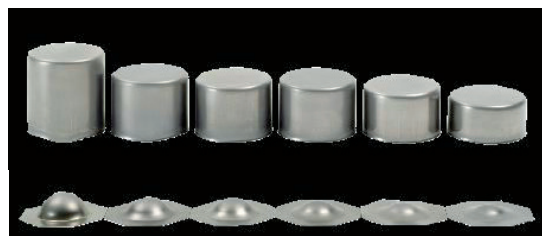

Figure 5. Maximum- cup height and dome height for deep drawing and stretch forming, respectively. Sheet steel grades (from left to right): CR4, CR600T-DP, CR800T- DP, CR1000T- DP, CR1200T- MS and CR1400T- MS.

The spring back effect is larger for high strength steel than for milder materials. Several methods to reduce spring back are possible, for example:

- over-bending
- increasing blank holder force
- using calibration step
- using draw beads
- adding stiffeners to flat areas and bends of the part
- using the correct blank shape

In the following sections of forming operations such as bending, roll forming, stamping and hole flanging, as well as some aspects regarding tool loads and galling using the Finite Element Method (FEM), are discussed. Recommendations for surface treatment and tool steel selection are also given.

BENDING

When bending a soft material, the resulting inner radius is determined mainly by the die width and not by the bending knife radius. A high strength material, on the contrary, follows the bending knife radius and the resulting inner radius is less dependent on the die width. Therefore, a larger die width can be used with high strength steels without compromising the required inner radius. This has a large influence on the bending force and also on the tool wear, which are both reduced when the die width is increased.

When transferring from softer to high strength sheet steel, the sheet thickness is generally reduced. The bending force may therefore remain unchanged, since the reduced thickness often compensates for the higher strength.

ROLL FORMING

Roll forming is extremely suited for advanced high strength steel. Experiments show that significantly sharper radii can be obtained using roll forming compared to conventional bending.

STAMPING

Press forces increase with increasing work material strength. Generally, a high strength material also requires higher blank holder force to prevent wrinkling. High surface pressure locally in the tool puts high demands on the tooling material and on the tool surface properties (refer also to section Overview page 9).

HOLE FLANGING

The hole flanging ability for high strength sheet steel is poorer than for softer materials. Because of this, it is more important to optimize the process as far as possible, for example by blanking the hole in opposite direction to the flanging direction. The burr is then located on the inside of the hole where it is least subjected to tension. Pre-forming before hole punching is another method to achieve higher flanging heights.

FEM – ANALYSIS OF TOOL LOADS AND GALLING

Numerical simulation using the Finite Element Method (FEM) can give valuable assistance in the selection of tool steel. One important question in tool steel selection is whether a sheet metal forming application can be performed without the occurrence of galling, which is often the dominating damage mechanism in sheet forming. The main reason for galling is too high contact pressure between the die and the sheet. The FE method can be used to calculate the contact pressure for a given combination of tool and sheet material. An example of a simulation of a successful application is shown in Figure 7. The application involves U-bending of 2 mm CR 800T- DP. The result indicates that the pressure limit for galling is 1200 MPa for this combination of sheet and tool material.

Choosing the right tool steel and surface treatment can increase the pressure limit for galling, allowing the forming of higher strength sheet material and/or more demanding geometries. The high nitrogen alloyed PM tool steel Uddeholm Vancron 40 SuperClean has a higher resistance to galling than conventional tool steel. The contact pressure limit when forming HR 700Y- MC and

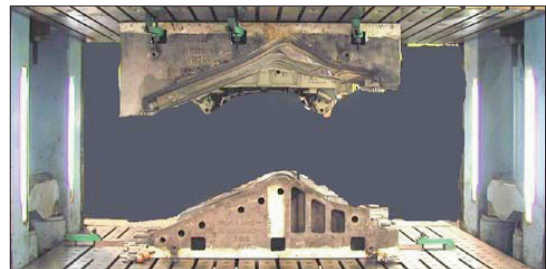

Figure 6. Complex stamping tool.

CR 800T-DP is approximately 1600 MPa when using Vancron 40 SuperClean material in the tool. As a rule of thumb, it can be assumed that the limiting pressure for galling is about 2.6 times the yield strength when using Vancron 40 SuperClean as tool steel material, but only 1.2 times the yield strength when using conventional tool steel materials such as AISI D2. This is valid for forming of sheet with strength up to CR 800T-DP, since above this strength, the temperature will increase and the lubricating film may no longer be able to carry the pressure.

With the present knowledge the limits for recommended use of Uddeholm Vancron 40 SuperClean can be stated as shown in Figure 8. Other important factors which will influence the galling limit are; choice of lubrication, surface roughness of the tool and sliding speed. One reason for the effect of the factors mentioned

here is that they all influence temperature, which should be kept as low as possible to avoid galling.

The pressure limit can be combined with a FEM simulation to predict whether an application (with a given geometry) will produce low enough contact pressure to be successful with a conventional tool steel, or if you have to use a more advanced tool steel like Vancron 40 SuperClean. However, a simulation that predicts low enough pressure is not a guarantee for success if the die surface preparation is poor. On the other hand, if the predicted contact pressure is just above the limit, improved lubrication, further reduction of the surface roughness or reduced forming speed can be sufficient to prevent galling.

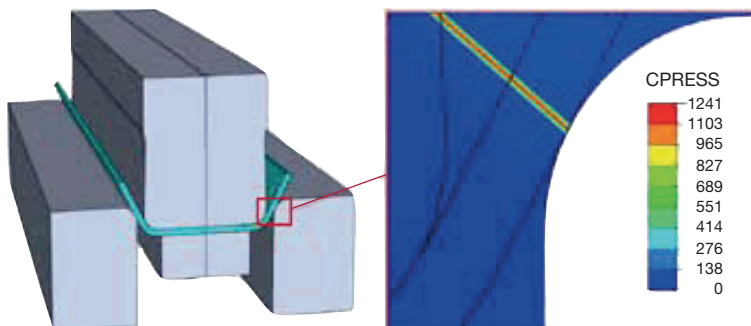

Figure 7. Computed die pressure distribution (MPa) from FE simulation of a U-bending application with CR 800T-DP.

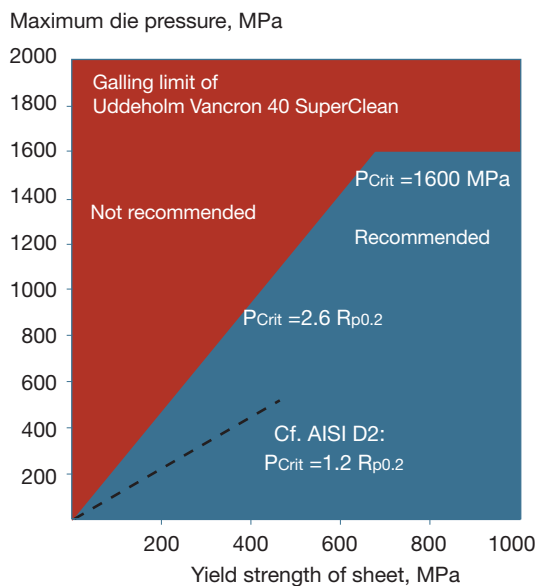

Figure 8. Limits to guide the use of uncoated Uddeholm Vancron 40 SuperClean to form carbon steel. Recommendations are based on application tests and FEM simulation. For comparison the approximate level of the galling limit of uncoated AISI D2 tool steel is included.

TOOL STEEL SELECTION AND SURFACE TREATMENT IN FORMING APPLICATIONS

In forming applications, galling, adhesive wear and plastic deformation are the most common failure mechanisms encountered. Forming of advanced high strength steel sheet (or thicker high strength sheet) means that higher press forces are needed due to the higher yield strength.

Forming tools with better galling resistance will be needed in the future as the trend is towards an increased use of higher strength sheet materials, higher press speeds, the use of progressive dies with fewer steps and the use of more environmentally friendly (but normally less effective) lubricants. Surface treatment such as PVD, CVD and TD coating on the forming tool is an effective way to prevent galling. Selection of the tool steel and the coating process used for forming advanced high strength sheet steels depend mainly on:

- the strength of the sheet steel
- the thickness of the sheet steel
- whether the sheet steel is coated or not
- the complexity of the forming operation
- the number of parts to be produced

At present, there is only limited experience with forming of advanced high strength steels. However, some preliminary tests with 2 mm CR600 –1000T- DP(GA) have indicated the following.

• Tool hardness levels

Tool hardness should be more than 58–59 HRC to counteract wear, galling and plastic deformation.

• Tool surface finish

Active tool surfaces should be polished to a low surface roughness ($R_a \leq 0.2 \mu\text{m}$).

• Conventional uncoated tool steels

These steels do not fulfil the requirements for press tools for uncoated sheet material. However, they might be suitable for simpler forming operations with thinner advanced high strength sheet material at the lower end of the strength range.

• Plasma nitrated conventional tool steels

Such tool steels do not show sufficient galling resistance for long production runs due to delaminating of the nitride layer. However, they might be suitable for simpler forming operations with thinner advanced high strength sheet material at the lower end of the strength range.

• PVD coated tools

PVD coatings in combination with a substrate steel having sufficiently high hardness ($>58 \text{ HRC}$) is one solution to avoid galling.

• CVD or TD coated tools

Properly prepared CVD or TD coated tools also avoid galling.

• Uddeholm Vancron 40 SuperClean forming tools

Uddeholm Vancron 40 SuperClean, which is a nitrogen alloyed, high performance PM steel, has shown very good industrial application results. Forming tooling (with a surface finish of $R_a \leq 0.2 \mu\text{m}$) made from Uddeholm Vancron 40 SuperClean usually performs much better than coated tooling.

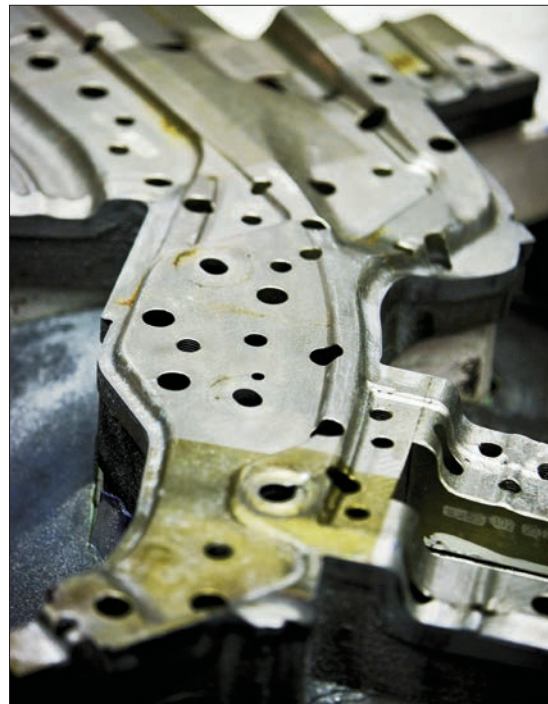

A summary of suitable tool steels for forming of advanced high strength steels is given in Table 4. Table data is based on experience to date but testing will be continued and table data will be regularly updated. The mentioned tool steel grades can be used as mono block dies or in combinations of base die material with inserts, depending on the size of the tool and the severity of the forming operation.

As stated earlier there is a need for surface treatment or surface coating to achieve proper performance of the tools. This means that the coatings are taking care of the wear (except for Uddeholm Vancron 40 SuperClean). The tool steel acts as a substrate for the coatings. The main demand on the substrate material is to support the very brittle coating, i.e. the substrate material must have enough compressive strength and hardness when the tool is put into service. Furthermore, the dimensional changes after the coating process must be negligible, or predictable to fulfil desired tolerances of the tool. Finally, the substrate mate-

rial has to withstand many cyclic loads at high stress levels, i.e. a high fatigue limit is needed.

To give some guidance for tool steel selection at different demands on serial length, a relative ranking of actual tool steel grades without and with coating is given in Table 5. In case of ion nitriding one of the factors, that has to be considered, is that the ductility is heavily deteriorated. A comparison of the ductility after nitriding to a case depth of 50 µm is made for the actual grades. As Uddeholm Vancron 40 SuperClean is used without any surface treatments it shows a very much superior rating than all other grades.

SHEET STRENGTH Rm (MPa)	STEEL GRADE Uddeholm /AISI/ W.-Nr.	SURFACE TREATMENT / COATING		TOTAL HARDNESS HRC
		Type	Serial length	
350–570	Calmax /-/ 1.2358	Nitriding/PVD	Medium runs	≥ 56
	Unimax	PVD/CVD	Medium runs	
	Sverker 21 /D2/ 1.2379	PVD/CVD	Medium runs	
	Caldie	PVD/CVD	Medium-long runs	
	Sleipner	PVD/CVD	Medium-long runs	
	Vanadis 4 Extra SuperClean	PVD/CVD	Long runs	
	Vanadis 8 SuperClean	PVD/CVD	Long runs	
	Vancron 40 SuperClean	No coating needed	All	
>570–800	Calmax /-/ 1.2358	Duplex (Nitriding + PVD)	All	≥ 58
	Unimax	PVD/CVD	All	
	Sverker 21 /D2/ 1.2379	PVD/CVD	All	
	Caldie	PVD/CVD	All	
	Sleipner	PVD/CVD	All	
	Vanadis 4 Extra SuperClean	PVD/CVD	All	
	Vanadis 8 SuperClean	PVD/CVD	All	
	Vancron 40 SuperClean	No coating needed	All	
>800–1400	Caldie	PVD/CVD	All	≥ 60
	Sleipner	PVD/CVD	All	
	Vanadis 4 Extra SuperClean	PVD/CVD	All	
	Vanadis 8 SuperClean	PVD/CVD	All	
	Vancron 40 SuperClean	No coating needed	All	

Table 4. Suitable tool steels for forming of advanced high strength steels.

UDDEHOLM STEEL GRADE	WITHOUT COATING					WITH COATING		WITH ION NITRIDING
	Wear resistance			Resistance to		Substrate material properties		
	Abrasive	Adhesive	Galling	Chipping/cracking	Plastic deformation	Fatigue limit	Dim. stability after re-hardening	Ductility after nitriding to 50 µm depth
Calmax	1	3	1	8	1	4	4	6
Unimax	1	4	1	10	1	5	7	7
Sverker 21	6	2	1	1	5	1	1	1
Caldie	2	5	2	8	5	9	7	5
Sleipner	5	4	2	3	8	2	4	3
Vanadis 4 Extra*	8	8	3	8	10	10	9	5
Vanadis 8*	10	8	5	6	10	9	9	4
Vancron 40*	6	10	10	6	10	9**	10**	10**

*Uddeholm SuperClean tool steel **Without any surface treatment.

Table 5. The table shows a relative performance ranking for the grades, both without and with surface coating. Relative scale = 1–10, where 10 is best.

CUTTING TOOL OPERATIONS

GENERAL

It is very difficult to give conclusive advice regarding tool steel selection for a specific production situation because production conditions in different plants will never be the same, even if the same part is being produced at each plant. The best way is to base the selection of the tool steel on the experience gained from earlier production runs using the same or similar production equipment.

Regarding advanced high strength steel, there is little previous experience to date to go on. As mentioned earlier, it is important not to base the tool steel selection on what was done for softer production materials using older grades such as AISI A2 or D2. Remember that there is a new generation of tool steels which are much more suitable for tooling when blanking and punching the advanced high strength steels.

In blanking and punching the main failure mechanisms usually are wear, chipping and galling. These failure mechanisms are influenced by:

- the strength of the production material
- the thickness of the production material
- the design features such as sharp radii
- the geometry of the part to be produced
- the number of parts to be produced

The tool must have sufficient hardness to prevent plastic deformation of the cutting edge. In addition, special attention must be given to the surface quality of the tool to prevent premature failure by chipping or cracking and also to prevent galling. In the following sections, cutting operations such as blanking, punching, cutting and shearing are discussed. Recommendations for surface treatment and tool steel selection are also given.

BLANKING AND PUNCHING

Appearance of a cut edge

Commonly used blanking and punching methods generate a cut edge consisting of a rollover, a burnish, a fracture zone and a burr. The burnish is smaller for high strength steel than for mild steel. The burr height is reduced with increasing tensile strength. An important factor to achieve a good edge is the die clearance.

Die clearance

The die clearance is the radial distance between the punch and the die, see Figure 10.

The edge is often characterized by the four sections illustrated in Figure 9. Compared to blanking/punching in mild steel, the choice of die clearance has a greater influence on the tool life. However, the burr formation is smaller and not significantly affected by changing the die clearance. The rollover and fracture zone will increase with increasing die clearance, but less than for mild steel. In Figure 11 the recommended die clearance for blanking and punching is shown.

In Figure 12, an edge can be seen after punching in CR 1400T-MS with 6% and 14% die clearance. In general, it is better to use a larger die clearance when blanking/punching high strength sheet steel. However, for the highest strength sheet steels a very large die clearance can be a disadvantage. This will be explained later.

When blanking/punching steels up to 1000 MPa tensile strength, a small die clearance gives a high amount of galling on the tool. A too large clearance gives less tool wear, but generates more bending or rollover in the work object resulting in lower edge quality. This is why the desired edge quality of the work object affects the choice of die clearance. The relation between tool wear and die clearance is shown in Figure 13.

When blanking/punching in the highest strength material, too small a die clearance also gives some galling on the tool, but the main wear mechanism is abrasive wear. Because of the material strength, there is a limit on how large the die clearance can be. Too large a die clearance generates high bending stresses on the punch edge, which increases the risk of chipping, see Figure 14. This is especially important in sheet materials with a small difference between yield and tensile strength as in the martensitic CR MS and MS-EG sheets.

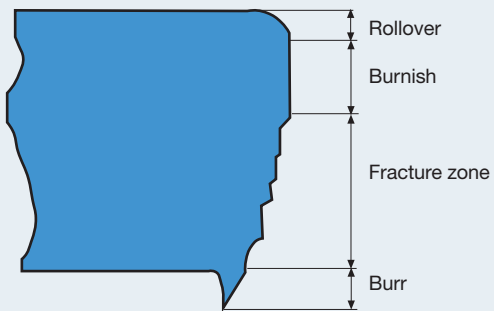

Figure 9. Appearance of a cut edge.

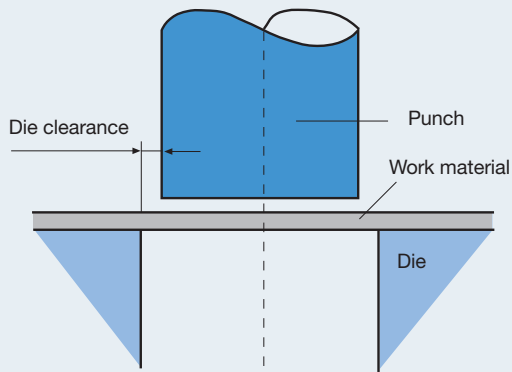

Figure 10. Die clearance definition.

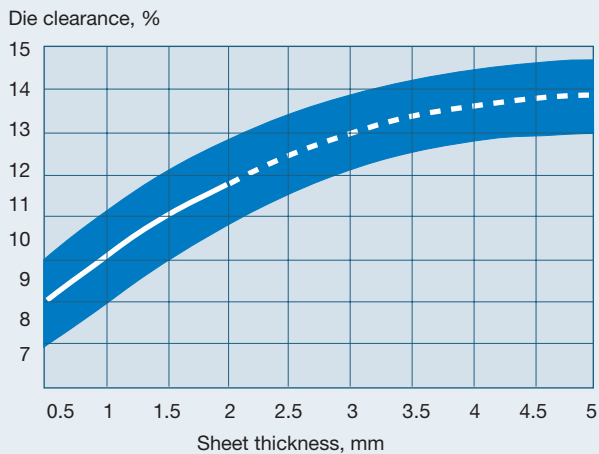

Figure 11. Recommended die clearance for blanking/punching advanced high strength steel.

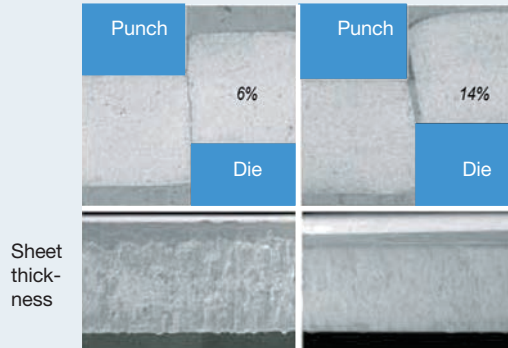

Figure 12. Edge cut with varying die clearance.

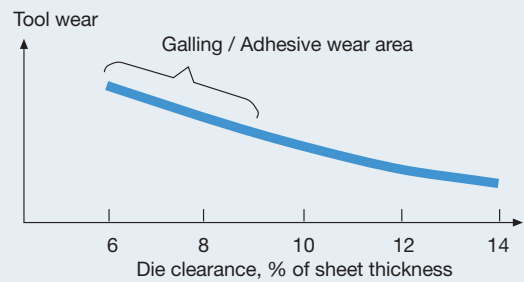

Figure 13. Relation between tool wear and die clearance when blanking in CR 800T-DP, sheet thickness = 1 mm.

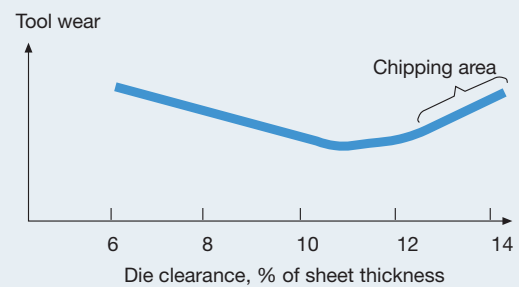
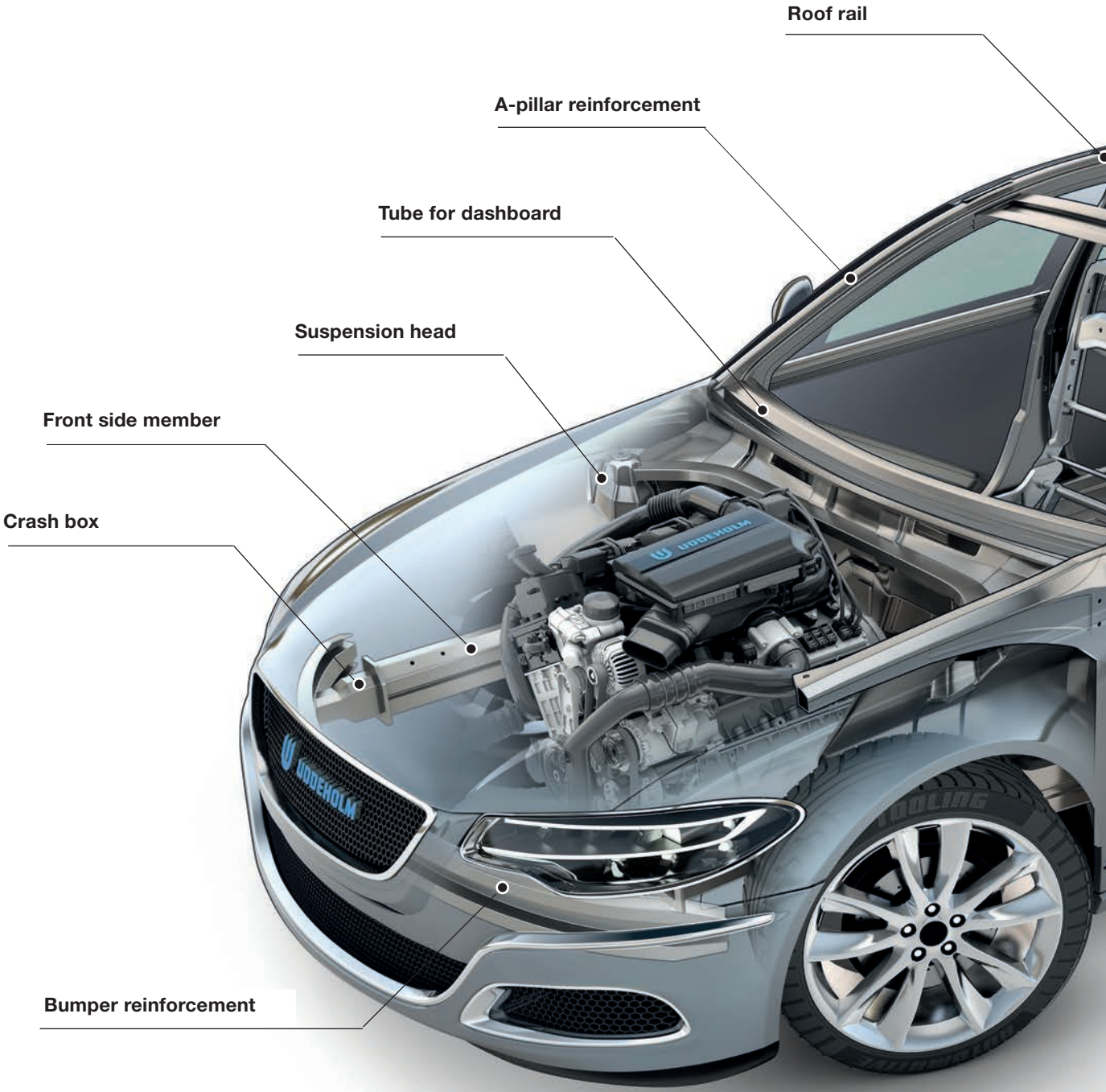
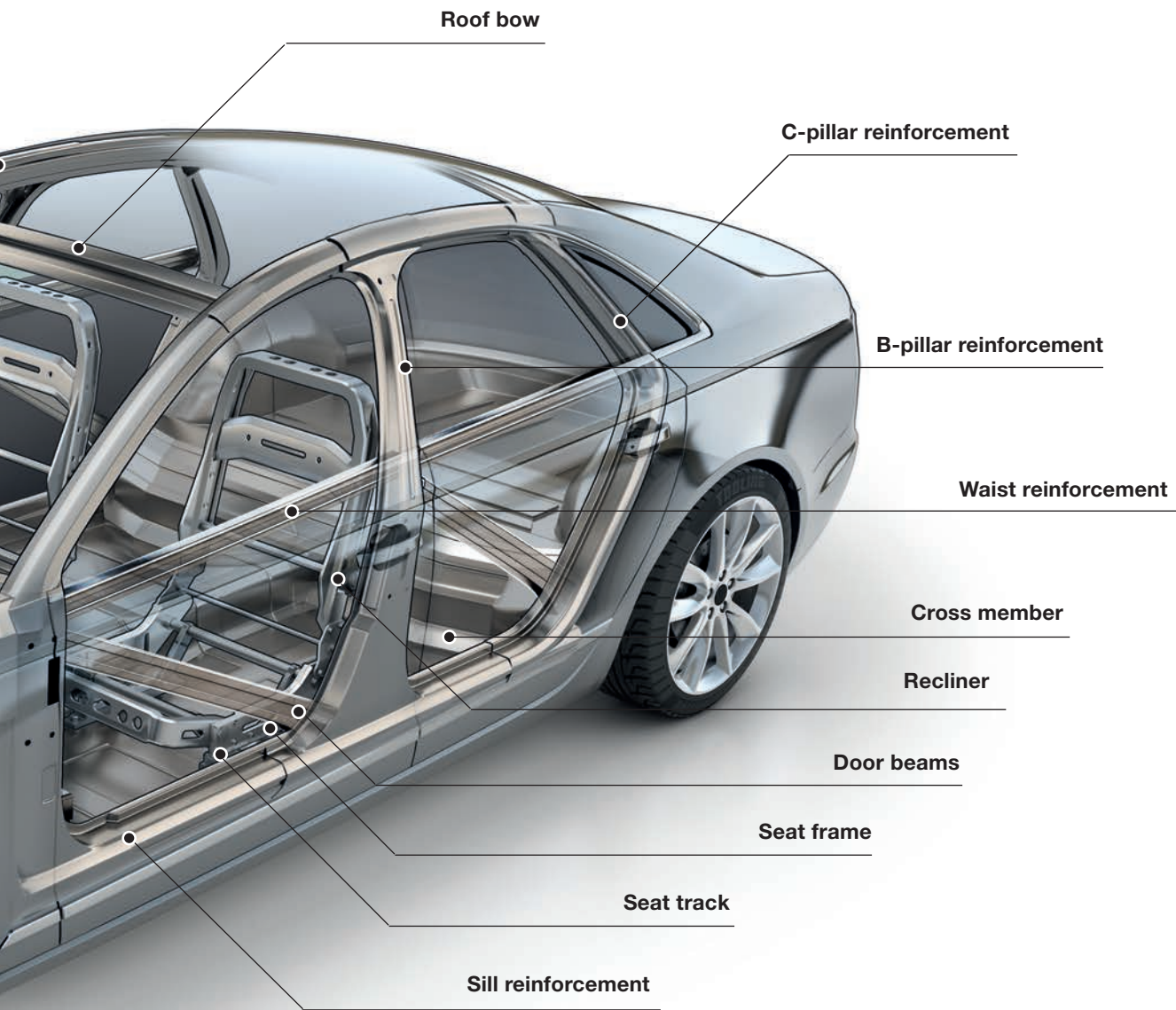

Figure 14. Relation between tool wear and die clearance when blanking in CR 1400T-MS, sheet thickness 1 mm.

The tool steels Uddeholm Caldie, Uddeholm Sleipner, Uddeholm Vanadis 4 Extra SuperClean, Uddeholm Vanadis 8 SuperClean and Uddeholm Vancron 40 SuperClean are typical grades used for manufacturing these car parts. Other grades can be used depending on factors like design, sheet steel type and thickness.





Blanking and punching force

The blanking/punching force required is proportional to the sheet steel strength, the sheet thickness and the length of the blanked/ punched line. In Figure 15 the varying punching force is shown when punching a \varnothing 5 mm hole in 1 mm thick sheet, with a 10% die clearance in advanced high strength steel. The blanking/punching force can be quite high when blanking/punching the hardest advanced high strength steel grades. However, the reduction of sheet thickness will normally compensate for the increased blanking/ punching forces.

When blanking/punching in the fully martensitic CR MS and CR MS-EG sheets, the force is higher and the work material ductility is low. This means that a shock wave or recoil force may be generated. This is noticed as a fast negative force amplitude as shown in Figure 15. The shock wave generates stress on the tool, which may lead to fatigue cracking after a relatively short time. This is shown in Figure 16. To avoid production disturbances, the effects of the high blanking/punching forces on the fittings and sharp radii should be considered, as well as the surface finish of the tool.

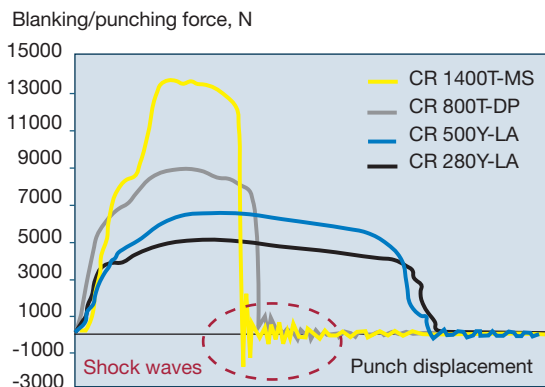
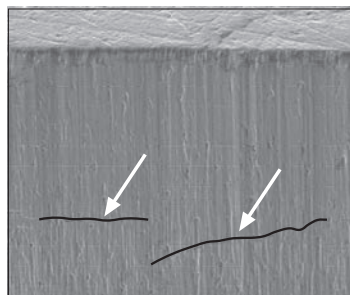

Figure 15. Blanking force and shock waves when punching advanced high strength steel grades.



When blanking/punching in advanced high strength steel with lower strength, the work material ductility is higher which reduces the effects of fatigue and cracking in the tool. For this reason, focus should be on the forces generated when blanking/punching advanced high strength steel with the highest strength and also how the forces can be reduced. Experiments have shown that the die clearance has a marginal effect on the blanking/punching force. However, the force is somewhat reduced with increased die clearance. Typically a 3 to 5% reduction of the force is possible to reach with an increased die clearance.

Reducing blanking/punching force

It is important to use the correct blanking/punching parameters. How to select the die clearance when blanking/punching is explained in section Die clearance, page 16. To avoid simultaneous blanking/punching when making several holes in one operation, the punches can be of different length. This reduces the required blanking/punching force which otherwise can be considerable. To coat the punching tool is not an effective way to reduce the force. On the contrary, the force can increase as shown in Figure 19.

A coated punch produces a higher blanking/punching force due to a lower friction between the end surface of the punch and the sheet surface. The lower friction makes the cracking initiation more difficult in the sheet, which increases the blanking/punching force. The increasing force facilitates fatigue cracking in the tool. When cracking starts the coating rapidly comes loose. The most effective way to reduce the force is to chamfer the tool.

Preferably this is made symmetrically to avoid inclined loads on the tool. Chamfering can also be a way to reduce noise. Different ways to chamfer the tool is shown in Figure 17 and Figure 18. How much the blanking/punching force can be reduced using symmetrically chamfered punches is shown in Figure 19.

Figure 16. Cracking developed as a result of fatigue.

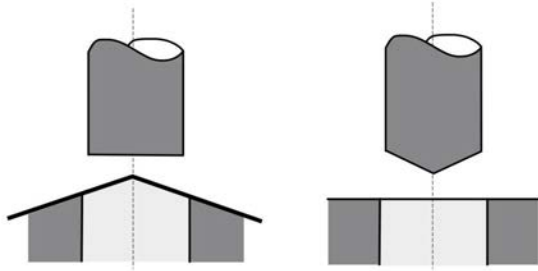

Figure 17. Chamfered tools for blanking and punching.

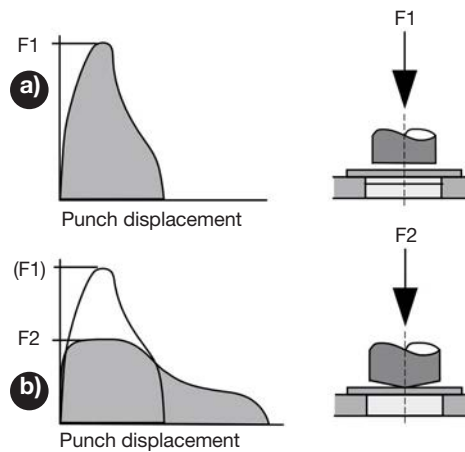

Figure 18. Blanking/punching force as a function of punch displacement for a) flat punch or b) chamfered punch.

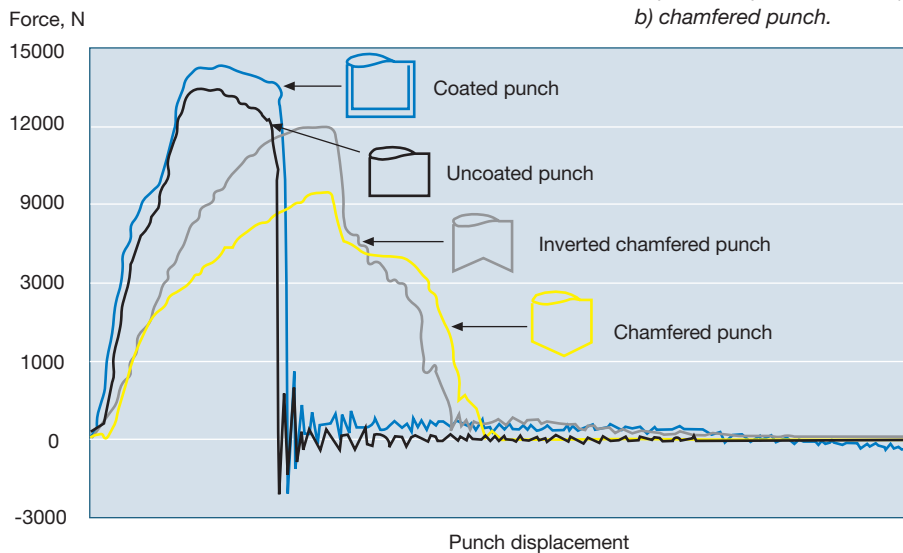

Figure 19. Effect of chamfering on blanking/punching force and shock waves when punching a $\varnothing 5$ mm hole in 1 mm thick CR 1400T-MS with 10% die clearance.

The blanking/punching force can be reduced by 30% for CR 1400T-MS with a chamfer of 0.7 times the sheet thickness. The size of the effect of a chamfered punch depends on the work material as shown in Figure 20.



	-4%	-13%	-25%	-30%
	-8%	-13%	-15%	-10%
	CR280Y-LA	CR500Y-LA	CR800T-DP	CR1400T-MS

Figure 20. Reduction in % of the blanking/punching force for different types of chamfering of the punch (height of chamfer 0.7 times the sheet thickness).

To obtain a larger reduction effect when blanking/punching mild steel the chamfering must increase to approx. 1–1.5 times the sheet thickness. The chamfer should not be unnecessarily

large when blanking/punching in advanced high strength steels, just large enough to start the cut before the whole punch end surface area is in contact with the sheet surface. Using an unnecessarily large chamfer will increase the risk of plastic deformation of the punch tip.

Another way to reduce the risk of plastic deformation is to use a chamfered punch with a flat centre section as shown in Figure 21.

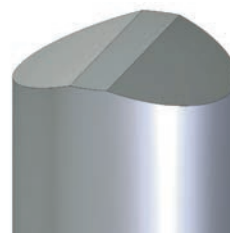

Figure 21. A chamfered punch with a flat centre section.

Note: Using a chamfered punch does not necessarily mean that the tool wear will be less. The main advantages are force and noise reductions.

SHEARING

Cutting clearance and shearing angle

In shearing the cutting clearance is the horizontal distance between the upper and lower shear, and the shearing angle is the angle between the upper and lower shear, see Figure 22. The shearing angle is normally applied on the upper shear.

In general, similar cutting clearance can be used as for softer sheet steel. The cutting clearance can be somewhat larger when using a shearing angle compared with parallel knives. Cutting clearances are usually smaller compared with blanking and punching. Recommended cutting clearances for advanced high strength sheet can be seen in Figure 23.

The selection of shearing angle can be seen in Figure 24 for different strength levels and sheet thicknesses.

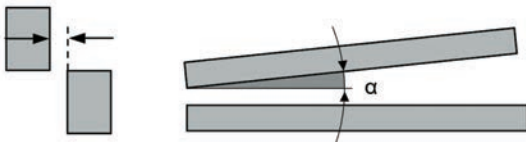

Figure 22. Cutting clearance and shearing angle respectively.

Appearance of cut edge of a sheet

The appearance of the cut edge of a sheet is similar as when blanking and punching, see section Blanking and punching on page 16. Typical sheet edge appearances for three sheet steel grades can be seen in Figure 25.

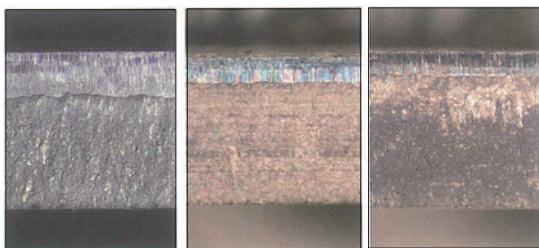

Figure 25. Sheet edge appearance for HR 700Y-MC, CR 800T-DP and CR 1400T-MS respectively in thickness 2 mm with 7% cutting clearance and 1° shearing angle.

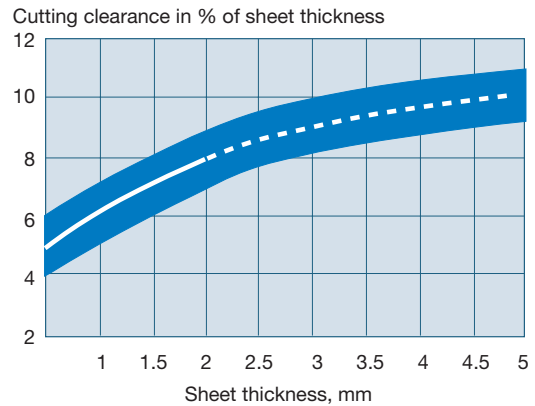

Figure 23. Recommended cutting clearance when shearing

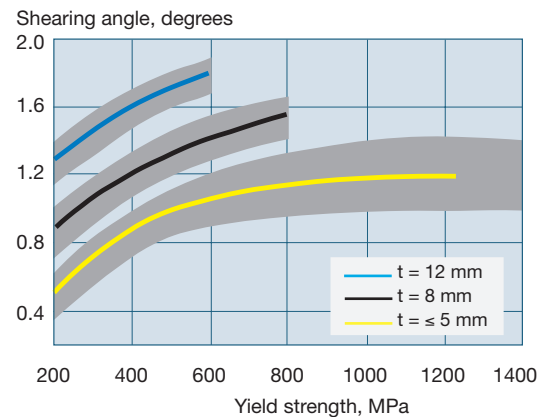

Figure 24. Recommended shearing angles depending on sheet thickness.

When changing the cutting parameters in shearing the sheet edge appearance changes as well. A larger cutting clearance with parallel knives gives a larger burnish. On the other hand, a larger cutting clearance when using a shearing angle will give a smaller burnish. When using a high shearing angle in combination with a large cutting clearance, splitting or tearing marks can sometimes be seen in the fracture zone, see the left photo in Figure 26.

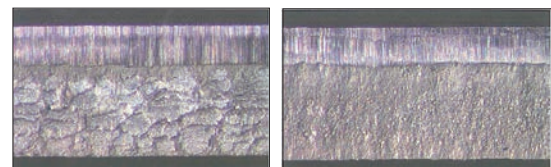

Figure 26. Sheet edge appearance for HR 700Y-MC, t = 2 mm with different cutting conditions. The left image indicates that cutting clearance and/or shearing angle is too large. The right image indicates that the cutting conditions are OK.

A large shearing angle when working in CR-MS sheets can sometimes result in a wavy pattern in the fracture zone, see Figure 27.

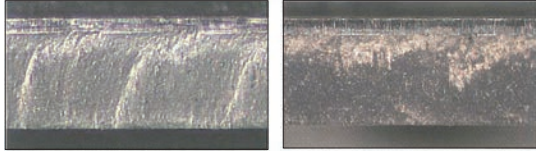

Figure 27. Sheet edge appearance for CR 1400T-MS, $t = 2$ mm with different cutting conditions. The left image indicates that cutting clearance and/or shearing angle is too large. The right image indicates that the cutting conditions are OK.

Shearing force

The shearing force required is proportional to the sheet steel strength, the sheet thickness and the length of the cut. The shearing force can be quite high when shearing the hardest advanced high strength steel grades. To avoid high shearing forces a shearing angle should be applied. As soon as a shearing angle is used the difference between advanced high strength sheet steel and mild steel is much smaller, see Figure 28. The cutting clearance has very little influence on the total shearing force. The largest force reduction is when going from a parallel shear to 1° shearing

angle. There is no benefit to use shearing angles $> 1.5^\circ$. The reduction in total shearing force is low but the tool edge load will be higher and will increase the risk of edge chipping.

In power shearing of advanced high strength steels, the first thing asked is often:

– Will I manage a transition from mild sheet steel to advanced high strength sheet steel with the production equipment I have?

An expression for the shearing force is needed to answer that question. For this purpose, the following equation can be used:

$$\frac{K_{sk} \cdot t^2}{2 \tan \alpha} = F$$

where:

F = shearing force

K_{sk} = shearing strength = $R_m \cdot e$ -factor

α = shearing angle

t = sheet thickness

The shearing strength is calculated as the tensile strength times the e-factor. The e-factor varies with the tensile strength of the material. For mild steels, corresponding to CR1, the e-factor equals 0.8, but for higher strength steels the e-factor decreases to 0.55 with a parallel shear. With a shearing angle it can decrease down to 0.3 for the highest strength sheet material grades.

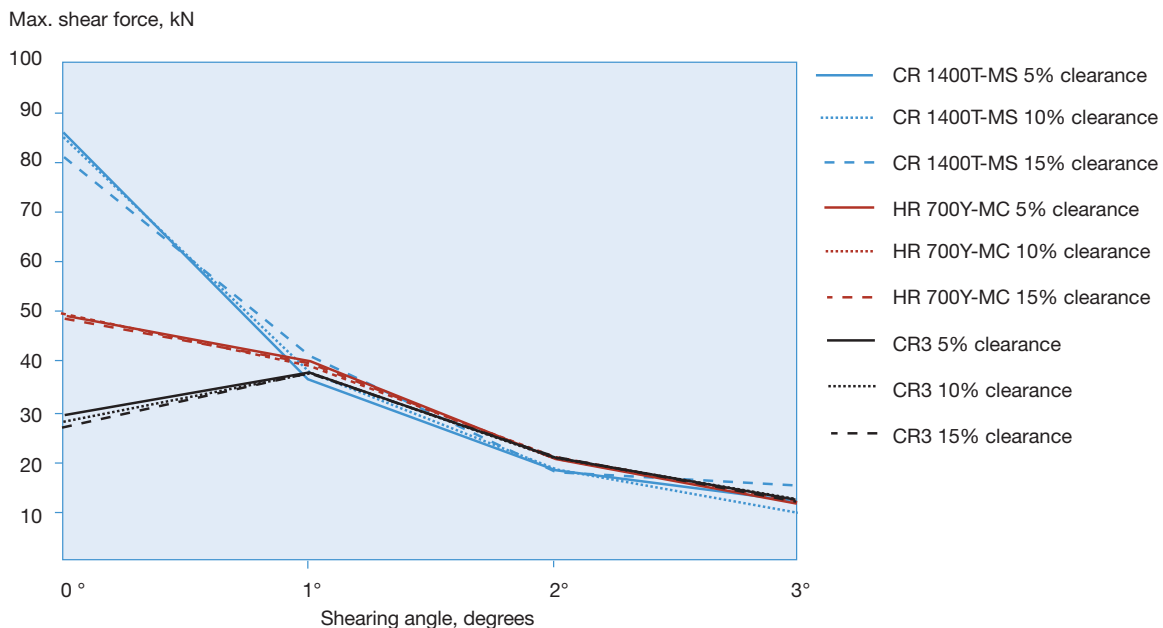

Figure 28. Shear force as a function of shearing angle for different cutting clearances. $t = 2$ mm.

In Figure 29 the e-factor is shown as a function of the work material tensile strength with both parallel shear and with a shearing angle. The e-factor is reduced significantly for advanced high strength steel when using a shearing angle.

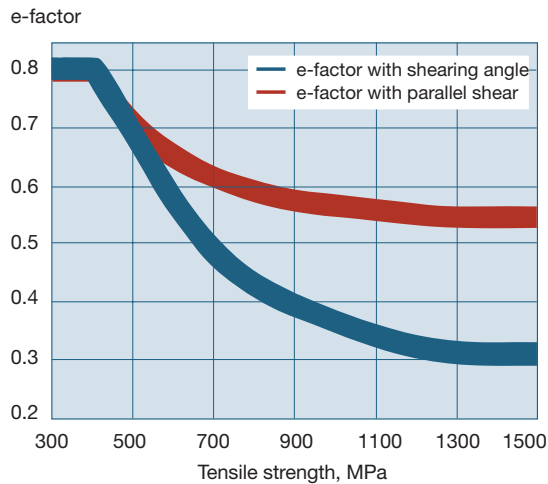

Figure 29. e-factor as a function of the work material tensile strength.

Example 1:

Mild sheet steel with a sheet thickness of 8 mm.
 Work material: HR 220Y (Rm = 350 MPa)
 Shearing force: $0.8 \times 350 \times 64 / 2 \tan 0.9 = 570 \text{ kN}$

Example 2:

Extra high strength sheet steel with the same sheet thickness = 8 mm
 Work material: HR 700Y-MC (Rm = 800 MPa)
 Shearing force: $0.47 \times 800 \times 64 / 2 \tan 1.5 = 459 \text{ kN}$

Example 3:

Extra high strength sheet steel with the sheet thickness reduced by 10% to = 7.2 mm
 Work material: HR 700Y-MC (Rm = 800 MPa)
 Shearing force: $0.47 \times 800 \times 51.84 / 2 \tan 1.5 = 372 \text{ kN}$

The examples show that the shearing force in fact decreases if you transfer from mild to extra high strength sheet steel (using a shearing angle in the same sheet thickness.) If you reduce the sheet thickness for the extra high strength sheet steel (with a moderate reduction of only 10% in example 3), the shearing force is reduced by ~35% from the original level.

TOOL STEEL SELECTION AND SURFACE TREATMENT IN CUTTING APPLICATIONS

Surface treatment

Whether to apply a coating on a tool or not is a question that often arises in tool making. But before a coating is applied, it is important to characterise the wear type. For advanced high strength steel, the type of wear differs depending on the microstructure and strength level. For dual phase steels, such as CR 800T-DP, the adhesive wear is dominating and a coating will certainly reduce the galling properties effectively, as shown in Figure 30. In hot dipped HR-MC sheets, the wear type is mixed with both adhesive and abrasive wear. If a HR sheet is to be blanked in unpickled condition the tool wear rate will be considerably higher and more abrasive. In any case, a coating will significantly reduce the tool wear when blanking in HR sheets.

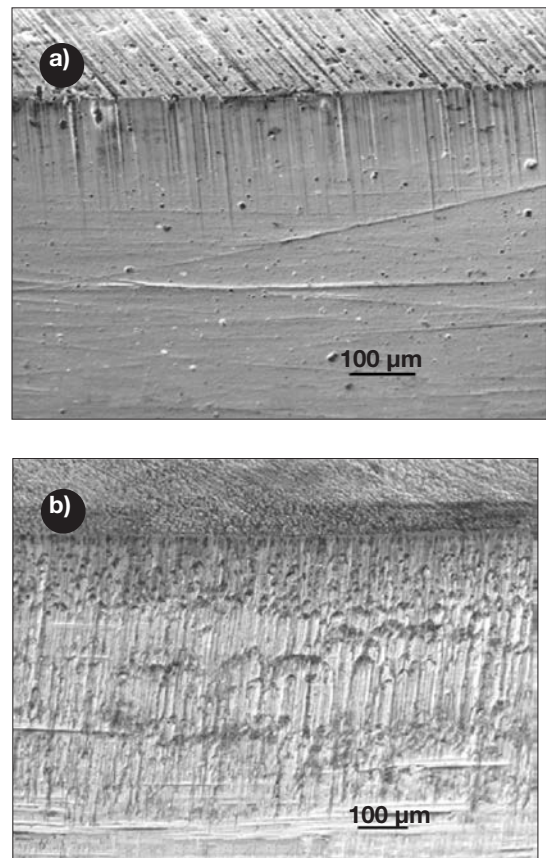

Figure 30. A blanking edge coated with a) PVD-coating (TiAlN) without galling and b) uncoated with galling after 200 000 parts produced in CR 800T-DP.

For the fully martensitic CR-MS grades, galling will not be the dominating wear mechanism. The wear type will be mainly abrasive and sometimes fatigue cracks can be present in the worn area, as shown in Figure 31.

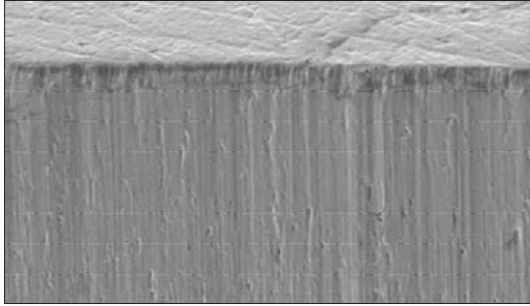
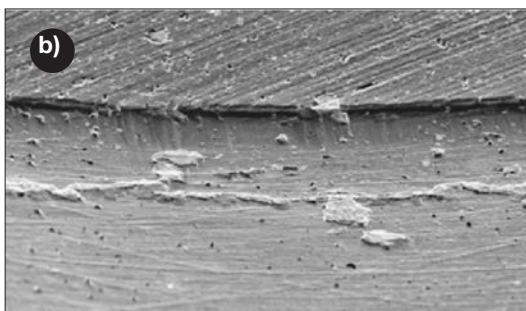
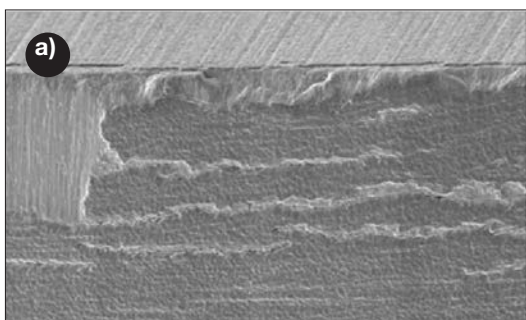

Figure 31. Typical tool wear of an uncoated blanking edge after 100 000 parts produced in CR 1400T-MS.

As long as fatigue cracks are generated, the coatings will not stay on the tool particularly long. If the preparation before applying a coating is optimized and the most suitable type of coating is applied, the result can be improved so that most of the coating is still present after 100 000 parts produced, as shown in Figure 32. However, for fully martensitic steels, such as CR-MS sheets, a coating will not give a significant benefit and is not recommended. In any case, nitriding of punch edges should be avoided due to a high risk of cracking the punch edges.



Tool steel selection

For tool steel selection purposes it is convenient to group the advanced high strength sheet steel materials as follows:

- HR-MC sheets
- CR-DP/DL and LA sheets
- CR-DP/CP + GI/GA sheets
- CR-MS and MS + EG/ZN sheets

This is because preliminary blanking/punching tests have revealed that each of the steel groups behave differently during blanking/punching, i.e. each group puts different demands on the tool material. To simplify access to needed information and reduce the risk of misunderstanding, the information relevant for a specific group is presented independently of the information valid for the other groups, although the same information to some extent will be repeated several times. The property profiles for these tool steels are given in table 3 page 11.

Figure 32. Appearance of a tool edge after 100 000 parts produced in CR 1400T-MS. a) shows a CVD TiCN coating, that has almost completely flaked off, b) shows a multi-layer TiAlN coating with somewhat better performance.

HR MC sheets

These sheet steel grades are hot rolled, micro alloyed steels with relatively high carbon content. They are available in pickled and non-pickled condition, with a thickness range from 2–12 mm.

Demands on the tool steel are:

- high wear resistance due to higher carbon content, strength and thickness. High wear resistance is particularly necessary for non-pickled material as the mill scale on its surface is very abrasive
- high chipping resistance, partly due to relatively high strength, but mainly due to the thickness range
- good galling resistance due to relatively high strength and thickness range

The HR MC sheets are the group that puts the highest demands on the tool material because the thickness range for these grades is by far the widest. For example with increased thickness and/or complexity of the part the hardness might have to be reduced to improve cracking resistance.

Appropriate grades as a guideline to tool steel selection are given in table 6.

HR SHEETS	UDDEHOLM STEEL GRADE	TOOL HARDNESS
HR 460Y-MC HR 500Y-MC HR 550Y-MC	Calmax Unimax Caldie Sleipner Sverker 21 Vanadis 4 Extra SuperClean Vanadis 8 SuperClean Vancron 40 SuperClean	> 56 HRC*
HR 600Y-MC HR 650Y-MC HR 700Y-MC	Calmax Caldie Sleipner Vanadis 4 Extra SuperClean Vanadis 8 SuperClean Vancron 40 SuperClean	≥ 58 HRC*
HR 900Y-MC HR 960Y-MC	Caldie Sleipner Vanadis 4 Extra SuperClean Vanadis 8 SuperClean	≥ 60 HRC*

* Tool hardness has to be selected carefully and adjusted both with thickness and complexity taken into account.

Table 6. Recommended tool steel grades for blanking HR sheets.

Below are some general aspects to consider for the recommended tool steel grades for the HR MC sheet steel grades.

- Uddeholm Calmax, Uddeholm Unimax and Uddeholm Caldie should be used when severe chipping is expected.
- Uddeholm Sleipner or Uddeholm Sverker 21 can be used for short to medium production runs with thinner sheet material when wear is the main concern.
- Uddeholm Vanadis 8 SuperClean can be used for long production runs when high wear resistance is the most important requirement.
- Uddeholm Vanadis 4 Extra SuperClean should be used when a strong combination of wear resistance and chipping resistance is needed, i.e. for long production runs with thicker and geometrically more complex parts.
- Uncoated Uddeholm Vancron 40 SuperClean should be used for long production runs to counteract galling when blanking/punching thinner, pickled sheet.
- Overlay coatings such as CVD or PVD can be used to counteract wear and galling. All of the above mentioned tool steel grades can be coated, but Uddeholm Vancron 40 SuperClean is normally used uncoated.
- Uddeholm Calmax can be CVD coated, but only PVD coated below 250°C (480°F).
- Nitriding is not recommended as this can easily cause tool edge chipping due to surface embrittlement.
- The hardness level used depends on the sheet thickness and the part geometry. It will normally be in the range 56–64 HRC.

CR- DP and LA sheets

The CR-DP sheet steel grades are cold-rolled dual phase steel with low carbon content. The LA grade is a microalloyed steel.

Demands on the tool steel are:

- high wear resistance due to the high sheet strength level
- high chipping resistance due to the high sheet strength level
- good galling resistance due to the high sheet strength level and the presence of ferrite in the sheet

Appropriate grades and recommended hardness levels for the different sheet strength levels are given in Table 7.

CR SHEETS	UDDEHOLM STEEL GRADE	TOOL HARDNESS
CR 500Y-LA CR 500T-DP	Calmax Unimax Caldie Sleipner Sverker 21 Vanadis 4 Extra SuperClean Vanadis 8 SuperClean Vancron 40 SuperClean	> 56 HRC
CR 600T-DP	Calmax Caldie Sleipner Sverker 21 Vanadis 4 Extra SuperClean Vanadis 8 SuperClean Vancron 40 SuperClean	≥ 58 HRC
CR 800T-DP CR 1000T-DP CR 1000T-DP +EG/ZN	Caldie Sleipner Vanadis 4 Extra SuperClean Vanadis 8 SuperClean Vancron 40 SuperClean	≥ 60 HRC

Table 7. Recommended tool steel grades for blanking CR sheets.

Below are some general aspects to consider for the recommended tool steel grades.

- Overlay coatings such as CVD or PVD can be used for all sheet materials to counteract wear and galling. All of the mentioned tool steel grades in table 7 can be coated, but Uddeholm Vancron 40 SuperClean is normally used uncoated.

- Uddeholm Calmax can be CVD coated, but only PVD coated below 250°C (480°F).
- Nitriding is not recommended as this can easily cause chipping.
- The hardness level used depends on the sheet thickness and the part geometry. It will normally be in the range 56–64 HRC.

For the 500 LA/DP and 600 DP sheet steel grades.

- Uddeholm Calmax, Uddeholm Unimax and Uddeholm Caldie should be used when severe chipping is expected.
- Uddeholm Sleipner and Uddeholm Sverker 21 can be used for short to medium production runs when wear is the main concern.
- Uddeholm Vanadis 4 Extra SuperClean should be used when a strong combination of wear resistance and chipping resistance is needed, i.e. for long production runs with thicker and geometrically more complex parts.
- Uddeholm Vanadis 8 SuperClean can be used for long production runs when high wear resistance is the most important requirement.
- Uncoated Vancron 40 SuperClean should be used for long production runs to counteract galling.

For the 800 DP and 1000 DP/DP+EG/ZN sheet steel grades.

- Uddeholm Caldie should be used to counteract chipping.
- Uddeholm Sleipner can be used for short to medium production runs with thinner sheet material when wear is the main concern.
- Uddeholm Vanadis 4 Extra SuperClean should be used when a strong combination of wear resistance and chipping resistance is needed, i.e. for long production runs with thicker and geometrically more complex parts.
- Uddeholm Vanadis 8 SuperClean can be used for long production runs when high wear resistance is the most important requirement.
- Uncoated Vancron 40 SuperClean should be used for long production runs to counteract galling.

CR- DP/CP + GI/GA/AS sheets

The CR- DP/CP + GI/GA/AS sheet steel grades are cold-rolled dual phase steel with low carbon content and are hot-dip galvanized. Demands on the tool steel are:

- high wear resistance is needed for long production runs but the wear is much less than with the non-galvanized grades, as the zinc coating acts as a lubricant
- high chipping resistance due to high sheet strength level
- good galling resistance due to high sheet strength level and presence of ferrite in the sheet

The soft, sticky zinc coating tends to adhere to the tool surface and should be cleaned off periodically.

Appropriate grades and recommended hardness levels for the different sheet strength levels are given in Table 8.

HOT DIP SHEETS	UDDEHOLM STEEL GRADE	TOOL HARDNESS
CR 460Y-LA GI CR 500Y-LA GI CR 500T-DP GI	Calmax Unimax Caldie Sleipner Sverker 21 Vanadis 4 Extra SuperClean Vanadis 8 SuperClean Vancron 40 SuperClean	> 56 HRC
CR 600T-DP GI CR 600T-CP GI CR 780T-CP GI	Calmax Caldie Sleipner Sverker 21 Vanadis 4 Extra SuperClean Vanadis 8 SuperClean Vancron 40 SuperClean	≥ 58 HRC
CR 800T-DP GI CR 1000T-DP GI	Caldie Sleipner Vanadis 4 Extra SuperClean Vanadis 8 SuperClean Vancron 40 SuperClean	≥ 60 HRC

Table 8. Recommended tool steel grades for blanking Hot-dip galvanized sheets.

Below are some general aspects to consider for the recommended tooling steel grades.

- Overlay coatings such as CVD or PVD can be used for all sheet materials, to counteract wear and galling. All of the mentioned tool steel grades in table 8 can be coated, but Uddeholm Vancron 40 SuperClean is normally used uncoated.
- Uddeholm Calmax can be CVD coated, but only PVD coated below 250°C (480°F).
- Nitriding is not recommended as this can easily cause chipping.

For the CR 460Y LA GI, CR 500Y LA/DP GI, CR600T DP/CP GI and CR780T CP GI sheet steel grades.

- Uddeholm Calmax, Uddeholm Unimax and Uddeholm Caldie should be used to counteract chipping.
- Uddeholm Sleipner or Uddeholm Sverker 21 can be used for short to medium production runs with thinner sheet material when wear is the main concern.
- Uddeholm Vanadis 4 Extra SuperClean should be used when a strong combination of wear resistance and chipping resistance is needed, i.e. for long production runs with thicker and geometrically more complex parts.
- Uddeholm Vanadis 8 SuperClean can be used for long production runs when high wear resistance is the most important requirement.
- Uncoated Uddeholm Vancron 40 SuperClean should be used for long production runs to counteract galling.

For the CR 800T DP GI and CR 1000T DPGI sheet steel grades.

- Uddeholm Caldie should be used to counteract chipping.
- Uddeholm Sleipner can be used for short to medium production runs with thinner sheet material when wear is the main concern.
- Uddeholm Vanadis 4 Extra SuperClean should be used when a strong combination of wear resistance and chipping resistance is needed, i.e. for long production runs with thicker and geometrically more complex parts.

- Uddeholm Vanadis 8 SuperClean can be used for long production runs when high wear resistance is the most important requirement.
- Uncoated Uddeholm Vancron 40 SuperClean should be used for long production runs to counteract galling.

CR MS and EG sheets

The MS and EG sheets are cold-rolled martensitic steel with low carbon contents. The EG grades have an electrodeposited zinc coating. These sheet steel grades are available in thickness from 0.5 to 2.1 mm.

Appropriate tool steel grades and recommended hardness levels for the different sheet strength levels are given in Table 9.

CR MS/EG SHEETS	UDDEHOLM STEEL GRADE	TOOL HARDNESS
1200T-MS 1400T-MS 1500T-MS	Caldie Sleipner	≥ 60 HRC
1200T-MS EG 1400T-MS EG	Vanadis 4 Extra SuperClean Vanadis 8 SuperClean	

Table 9. Recommended tool steel grades for blanking CR MS EG sheets.

Below are some general aspects to consider for the recommended tooling steel grades.

- Uddeholm Caldie should be used to counteract chipping and cracking.
- Uddeholm Sleipner can be used for short to medium production runs with thinner sheet material when wear is the main concern.
- Uddeholm Vanadis 4 Extra should be used when a strong combination of wear resistance and chipping resistance is needed for long production runs.
- Uddeholm Vanadis 8 SuperClean can be used for long production runs when high wear resistance is the most important requirement. Mainly for simple part geometries being blanked/punched from thinner sheet material.
- Coatings are not recommended for the CR MS and EG grades as present experience has shown that these flake off at a relatively early stage due to the formation of fatigue cracks in the tool surface.
- Nitriding is not recommended as this can easily cause chipping.

APPLICATION EXAMPLES

B-PILLAR

COLD WORK OPERATIONS	BLANKING AND BENDING
Work material	CR 800T-DP
Work material thickness	2.0 mm
Number of parts produced per year	82 000
Tool material in left blanking punch	Uddeholm Sleipner
Tool material in right blanking punch	Uddeholm Sverker 21
Tool material in left blanking die	Uddeholm Sleipner
Tool material in right blanking die	Uddeholm Sverker 21
Hardness of left and right blanking tool	HRC 62
Hardness of hole punch	HRC 60
Tool material in left forming tool	Uddeholm Vancron 40 SuperClean
Tool material in right forming tool	Uddeholm Sleipner + CVD, TiC + TiN
Hardness of left forming die	HRC 62
Hardness of right forming die	HRC 62
Surface roughness of forming tools	Ra 0.1 µm
Lubrication	8% oil emulsion

RE INFORCEMENT

B-pillar reinforcement tool with two choices of tool steel material. Both choices are proven to run smoothly.



B-pillar reinforcement. Courtesy of Finnveden Metal Structures, Olofström, Sweden.

COLD WORK OPERATIONS	BLANKING AND BENDING
Work material	CR 1000T-DP
Work material thickness	2.0 mm
Number of parts produced per year	300 000
Tool material in blanking tool	Uddeholm Vanadis 4 Extra SuperClean
Hardness of blanking tool	HRC 60
Tool material in forming tool	Uddeholm Vancron 40 SuperClean
Tool material in right forming tool	Uddeholm Vanadis 4 Extra SuperClean + CVD, TiCN
Hardness of forming tool	HRC 60
Surface roughness of forming tools	-
Lubrication	-

TOOLING FOR BUMPER TO PASSENGER CAR



Bumper for passenger car. Courtesy of Essa Palau, Barcelona, Spain.

COLD WORK OPERATIONS	BLANKING AND BENDING
Work material	CR 1400T-MS
Work material thickness	2.0 mm
Number of parts produced per year	82 000
Tool material in blanking punch	Uddeholm Sleipner
Tool material in blanking die	Uddeholm Vanadis 4 Extra SuperClean
Hardness of blanking tool	HRC 60
Tool material in forming punch	Uddeholm Sleipner
Tool material in forming die	Uddeholm Vanadis 4 Extra SuperClean
Hardness of forming punch	HRC 58
Hardness of forming die	HRC 60
Surface roughness of forming tools	-
Lubrication	No additional lubrication

TOOLING FOR TOW HOOK BRACKET



Tow hook bracket. Courtesy of Finnveden Metal Structures, Olofström, Sweden.

LUBRICATION

FORMING TOOL OPERATIONS

In forming, the friction between two surfaces in relative motion can be reduced by lubricating the surfaces. The most common lubrication type in stamping sheet steel is mixed lubrication, in which the lubricating film thickness allows for contact between the peaks of the tool and the work material surface. The lubricant is locked up in the irregularities in the surface, and together with the surface peaks, takes up the contact pressure in the forming process. This puts demand on the work material surface roughness (for cold rolled material, EN 10130 – normal surface is valid), and the lubricant's ability to neutralise newly developed reactive surfaces.

The viscosity of the lubricant has a large impact on sheet forming process. Low viscosity lubricants (25–50 cSt) are used for simpler sheet forming operations, but for more demanding stamping operations, a higher viscosity lubricant should be used.



The influence of lubricant viscosity on drawing. Maximum cup height using lubricant viscosity 500 cSt (left cup) and 40 cSt (right cup).

CUTTING TOOL OPERATIONS

The importance of using additional lubricants depends on several factors when blanking/punching and cutting/shearing advanced high strength steel. Steel grade, sheet thickness and sheet surface have a large influence as well as the tool geometry. In general, lubrication is more important for lower sheet strengths, thicker material and more complex blanking/punching shapes, for example, hole punching with sharp radii in a thick sheet material.

Recommended lubricants for blanking/punching in advanced high strength steel are types that resist high contact pressure. The need for additional lubricants differs depending on sheet grades as indicated below.

HR MC SHEETS

For hot rolled sheets the use of additional lubricant will benefit the tool life. In particular thicker sheets the lubricant can also reduce the cutting force as well as the retraction force due to lower friction.

CR DP AND LA SHEETS

It is good practice to use lubricants when blanking/punching advanced high strength steel of this type. The ferrite content of these steels introduces a certain amount of sticking on the punch tool, which can be reduced by using additional lubricants.

CR GI/GA SHEETS

The need for lubricants is less when blanking/punching hot-dip galvanized sheet materials. The galvanized surface offers a certain lubricating effect. The zinc coating tends to adhere to the tool surface after some production time and should be cleaned off periodically.

CR MS (EG/ZN) SHEETS

For fully martensitic cold rolled sheet grades such as CR MS, the need for additional lubricants is small. The delivery oil gives adequate lubrication for blanking/punching and cutting/shearing. These sheet grades do not have a tendency to stick onto the tool.

The need for lubricants is even less when blanking/punching hot-dip galvanized sheet materials. The galvanized surface offers a certain lubricating effect. The zinc coating tends to adhere to the tool surface after some production time and should be cleaned off periodically.

TOOLING ECONOMY

It is very important that a tool produces the required number of parts with a minimum of down time. Production stoppages due to tool breakage or frequent refurbishing cause costly production delays and lower productivity in general. There are several possible issues with the tooling.

The chain from tool design to tool maintenance must remain intact – any weak link can lead to deficiencies. One very important link is the tool material. The tool material has to have the right properties for the application and be of a consistent high quality in order to give reliable tooling.

Advanced tool steel manufacturing processes such as powder metallurgy, ESR and high quality conventional metallurgy mean that extra efforts are made during the production of the tool steel which result in steels that are more expensive than standard grades. However, it should not be forgotten that the tool steel cost is only a small fraction of the total cost of producing a tool – it is only the tip of the iceberg!

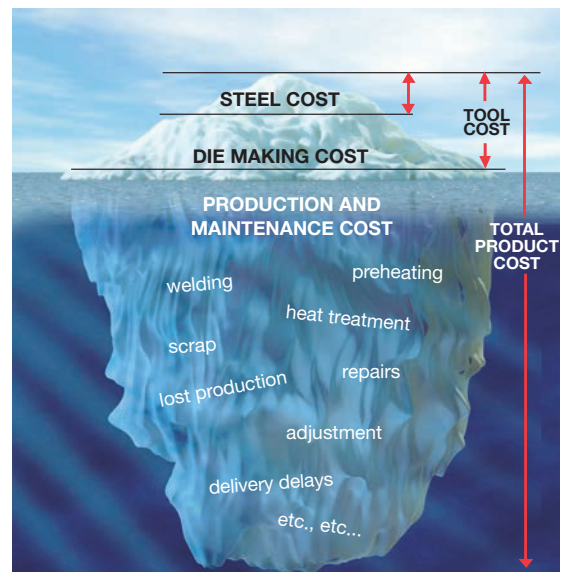

Tool steel cost — only the tip of the iceberg.

If the production costs, including costs for stoppages and maintenance for a certain batch size are considered; the use of a higher quality tool steel will lead to a small increase in the cost of the tooling, but usually give a large return on the investment. This is illustrated in the following graph.

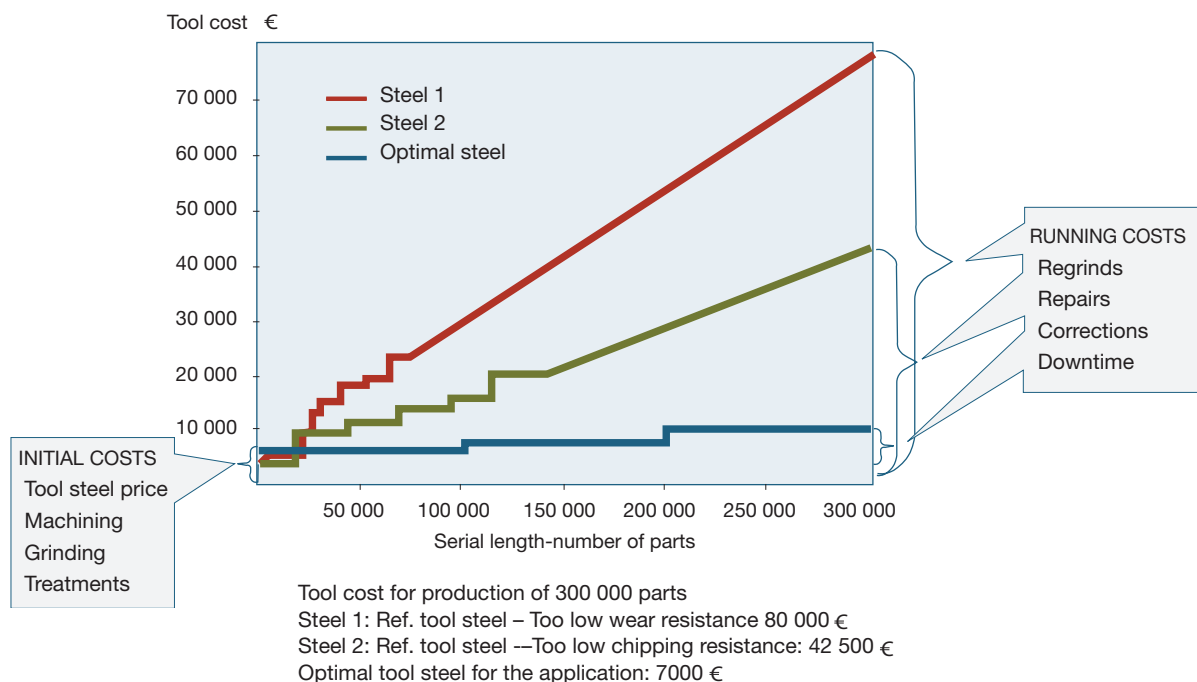

Total tool cost considerations. Steps in lines indicates cost for refurbishment.

TECHNICAL SUPPORT

EXPERTS TO HELP YOU

Uddeholm can help you put the benefits of advanced high strength steels to full use.

Our experts have many years of experience in selecting the proper tool steel for use with advanced high strength steel in cold work applications.

When changing over to advanced high strength steel, it is important to integrate the material selection, design and production processes right from the beginning. It is then possible to optimize the product and production process from both a technical and economical viewpoint.

Our experts in the Technical Service Centre and other areas have a deep knowledge and experience in tool steel selection, heat treatment of tool steels and surface treatments. In the case of tool failures, investigations can be made to explain and overcome actual tooling deficiencies.

The experts at the local sales offices can provide advice and solve tooling issues through direct local visits.

ADVANCED RESOURCES FOR ANALYSIS

Our company has the very latest equipment to quickly assist customers to choose the right tool steel with the right heat treatment solution.

THE FACILITIES INCLUDE

- Complete Laboratory

A complete laboratory for material investigations and product development. The laboratory includes a metallographic department with transmission and scanning electron microscopes, a mechanical strength laboratory with both static and fatigue test machines. It also includes a machining laboratory for evaluation and development of machining and grinding guidelines for our tool steels.

- Finite Element Method

Finite Element Method simulations of tool loads. FEM is used for simulation of sheet forming mainly for computation of tool loads. Predictions of galling is the main issue.

COURSES AND SEMINARS

Uddeholm regularly arrange courses and seminars on how the opportunities offered by advanced high strength steel can be put to use.

- Tool steel course that offers fundamental knowledge of tool steel production, tool steel treatments, properties, applications and tool steel selection.
- Seminars tailored for individual companies.

TECHNICAL INFORMATION

Information about Uddeholm tool steel grades, their treatments and how to select a certain grade are given in product brochures, treatment brochures and cutting data recommendations. Examples of Uddeholm treatment brochures are:

- Heat treatment of tool steel
- Welding of tool steel
- EDM of tool steel
- Grinding of tool steel
- Polishing of mould steel

Uddeholm has a large number of sales offices and agents all over the world. Product information and questions can always be handled locally by our local experts.

Our technical information and guidelines can also be found on www.uddeholm.com or in the Uddeholm app available for iPhone and Android smartphones.

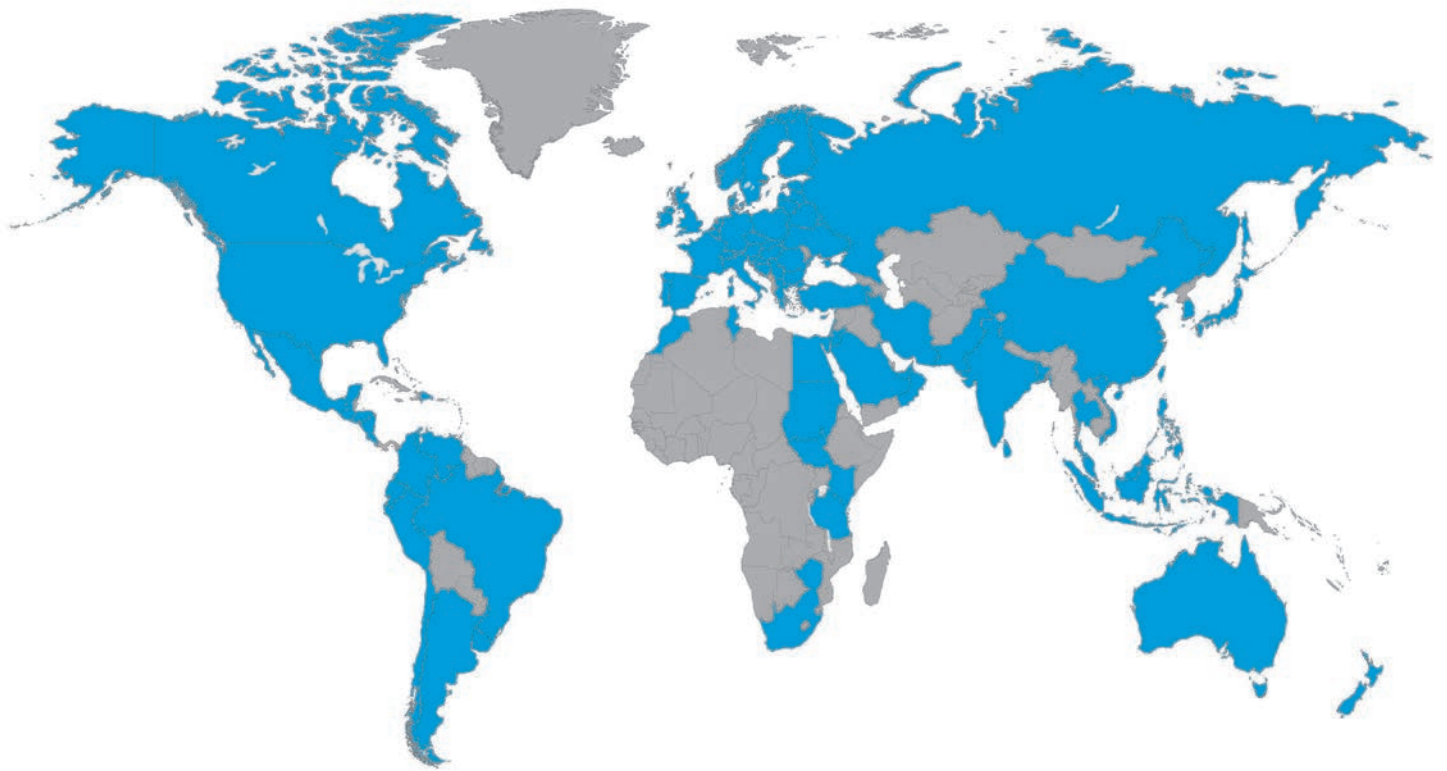

NETWORK OF EXCELLENCE

Uddeholm is present on every continent. This ensures you high-quality Swedish tool steel and local support wherever you are. Our goal is clear – to be your number one partner and tool steel provider.

Uddeholm is the world's leading supplier of tooling materials. This is a position we have reached by improving our customers' everyday business. Long tradition combined with research and product development equips Uddeholm to solve any tooling problem that may arise. It is a challenging process, but the goal is clear – to be your number one partner and tool steel provider.

Our presence on every continent guarantees you the same high quality wherever you are. We act worldwide. For us it is all a matter of trust – in long-term partnerships as well as in developing new products.

For more information, please visit www.uddeholm.com