

# CyMill

NC MILLING HEADS



COMPONENTS  
EXCELLENCE



MADE IN GERMANY



**PROCESS STABLE  
RELIABLE  
DYNAMIC  
STRONG**



# DYNAMIC MEETS PRECISION

**The CYTEC machining heads with synchronous drives for high dynamic applications are the result of long-term experience gained in the conception and design of torque motors produced by CYTEC Zylindertechnik GmbH.**

CYTEC optimised them once more as latest generation of direct drives for rotating and swivel axes.

The distinctive characteristics of the series are performance, precision and a high level of reliability together with enormous power and dynamic.

The drives are characterised by optimal control properties. A high overload capacity adapts ideally to most application requirements.

The powerful drive clamping device supports high precision positioning even for rough machining and high workpiece loads.



**CYTEC Zylindertechnik GmbH is a proven system partner for the mechanical engineering, technical know-how and creativity gained over decades working in the machine tool industry.**

The range of products comprises hydraulic and pneumatic clamping systems with positive lock, motor spindles, NC rotary tables and not at least single or multiple axis NC milling heads with ultra-high dynamic, patented direct drives. CYTEC Zylindertechnik GmbH is developer and producer of tool machine components, that meet highest technical demands. Its in-house production depth and flexibility guarantee highest product quality.

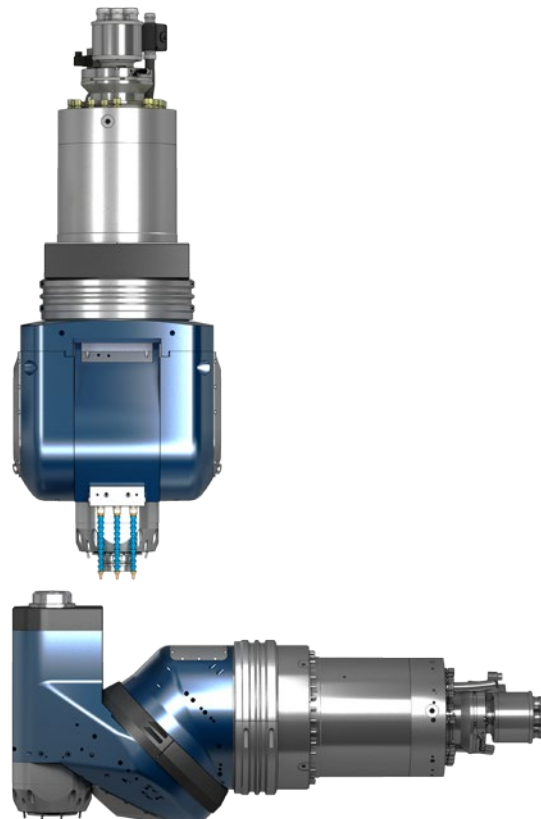

# THE RIGHT HEAD FOR ANY APPLICATION

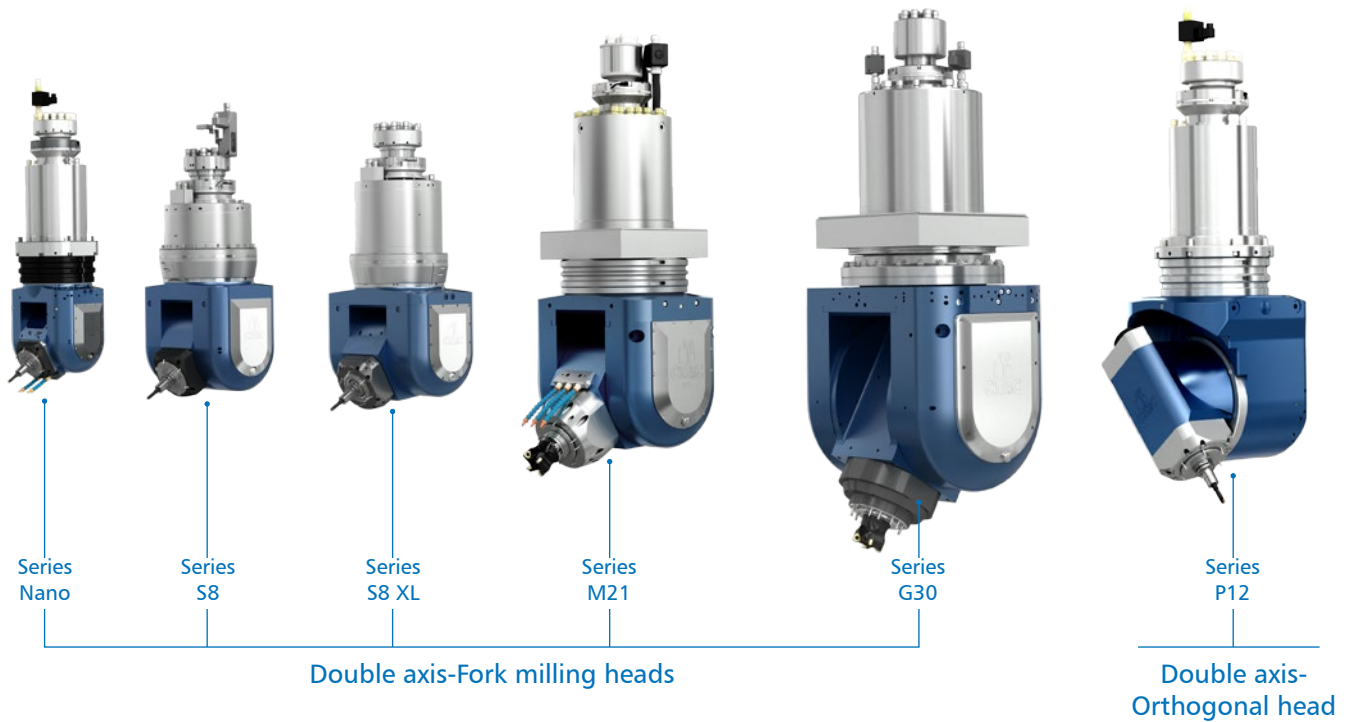

## Content:

Introduction.....	3
Overview.....	4
At a glance .....	6
Series:	
Fork head Nano .....	8
Fork head S8.....	9
Fork head S8 XL.....	10
Fork head M21 .....	11
Fork head G30 .....	12
Universal head M21 XL single axis.....	13
Universal head M21 double axis.....	14
Universal head M21 XL double axis.....	15
Universal head M21 single axis .....	16
Orthogonal head P12 .....	17
Overview motor spindles.....	18

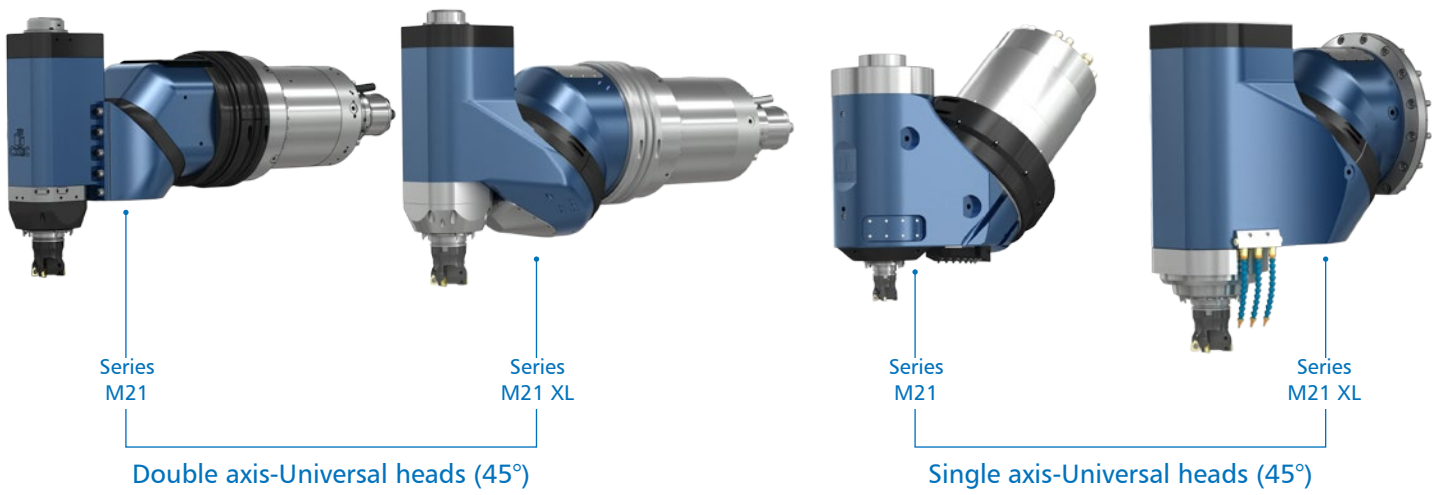

## Options



Automatic spindle exchange



Automatic head exchange

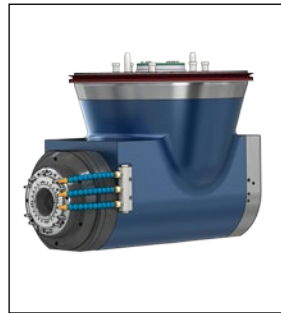

Horizontal head



Vertical head



Suction device

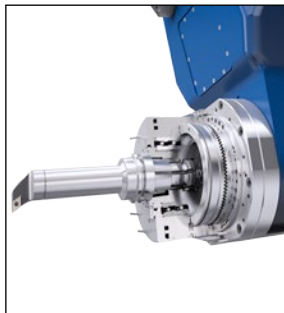

Mill/turning function

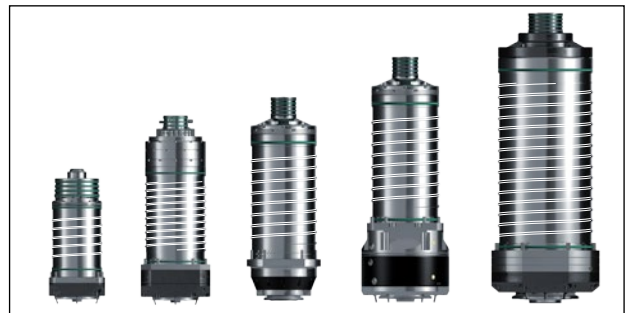

High speed or high torque spindles

# AT A GLANCE

- **Milling heads in individual configuration**

- adapted to the application
- single and double axis systems
- fork, universal and orthogonal versions

- **Highest possible precision**

- by means of
  - radial/axial roller bearings
  - state of the art measuring systems
  - high torsional stiffness

- **Integrated security pack**

- in terms of a complete sensor system for total monitoring of all functions during the operational process



## UHT DirectDrives

- **UltraHighTorque direct drives of the latest generation**

- modular systems
- for maximised power and dynamic
- effective cooling solutions in A-/C axis
- powerful hydraulic clamping
- products of long term CYTEC experience and knowhow

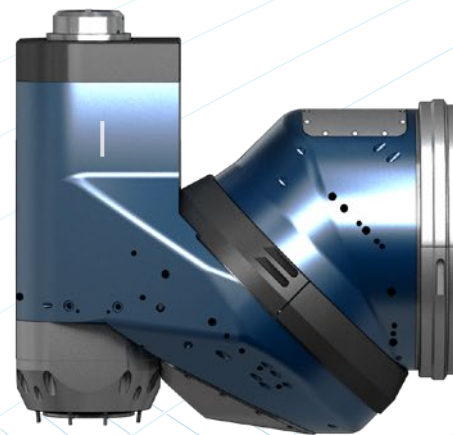

⦿ **High system rigidity**

as a result of extensive FEM calculation:

- simulation of various stress situations caused by different loads and machining processes
- optimised weight-reduced structure
- for best machining quality and trouble free operation

⦿ **Standard and optional main spindles**

for various requirements;

sizes/adaption/design available according to customer demands, possible with:

- clampable spindle shaft
- modification of the tool interface
- power range up to 70 kW
- rotational speed up to 24.000 min<sup>-1</sup>

⦿ **Cartridge axis housings**

and sealings as reliable protection device from harmful external influences and dirt

⦿ **Effective simultaneous machining**

⦿ **Intelligent energy line/ data transmission concept**

- elaborated internal arrangement with flexible wiring/tubing
- complete flexible cable harness - at least 2m length
- i. e. simple integration into the existing customer machine periphery

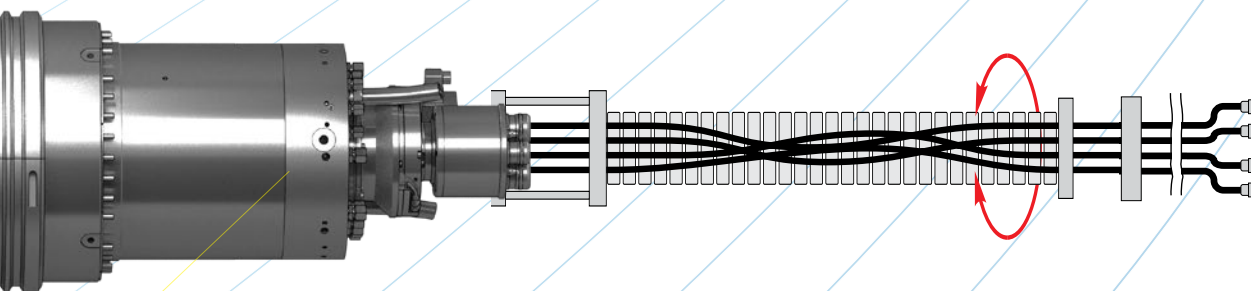
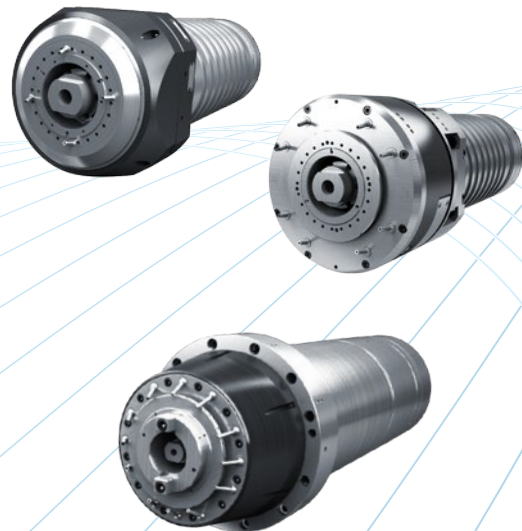

MADE  IN GERMANY



## Fork milling head Series Nano

	A axis	C axis
Nom./max. torque [Nm]:	164/308	490/820
Nom. current [A]:	26	30
Clamping torque 60 bar [Nm]:	700	2,500
Swivel angle [°]:	±115	±360
Measuring system:	absolute	absolute
Positioning accuracy [″]:	±5	±2
Total weight appr. [kg]:	290	

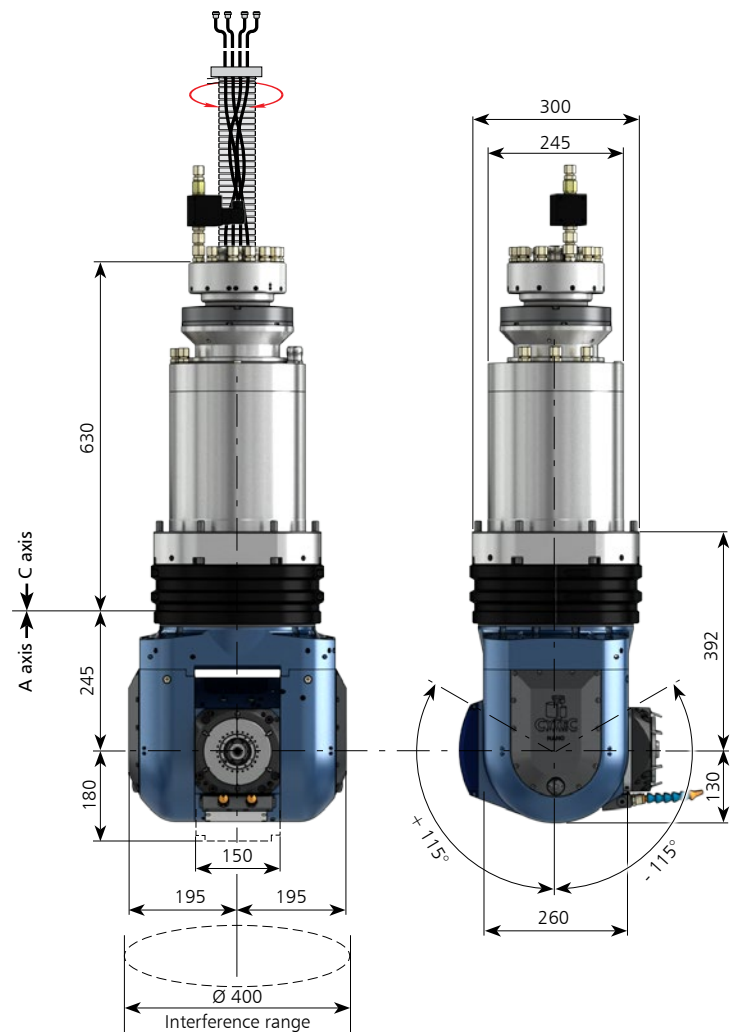



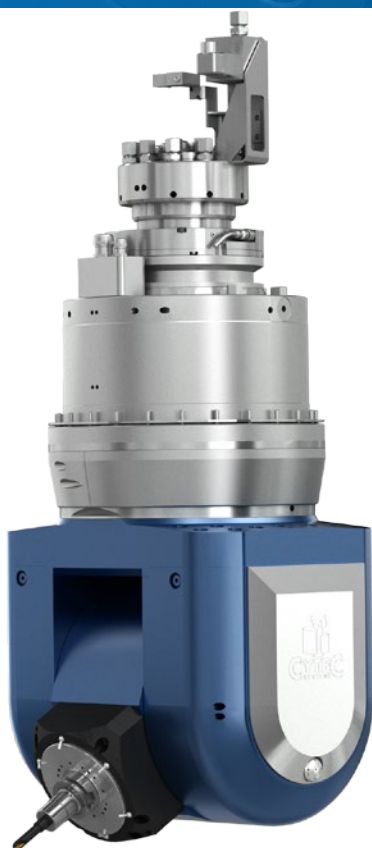

## Fork milling head Series S8

	A axis	C axis
Nom./max. torque [Nm]:	400/770	430/820
Nom. current [A]:	26	14
Clamping torque 60 bar [Nm]:	1,500	1,400
Swivel angle [°]:	±110	±360
Measuring system:	absolute	absolute
Positioning accuracy [″]:	±5	±2
Total weight appr. [kg]:	350	

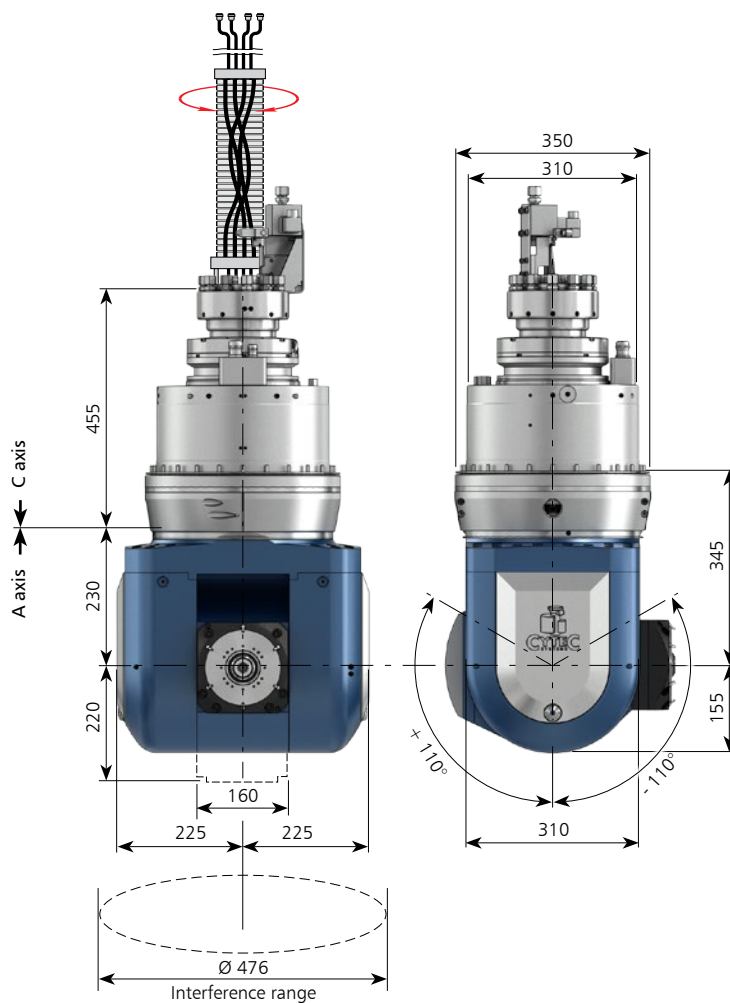



## Fork milling head Series S8 XL

	A axis	C axis
Nom./max. torque [Nm]:	630/1,190	670/1,320
Nom. current [A]:	27	15
Clamping torque 60 bar [Nm]:	2,400	2,400
Swivel angle [°]:	±110	±360
Measuring system:	absolute	absolute
Positioning accuracy [″]:	±5	±2
Total weight appr. [kg]:	495	

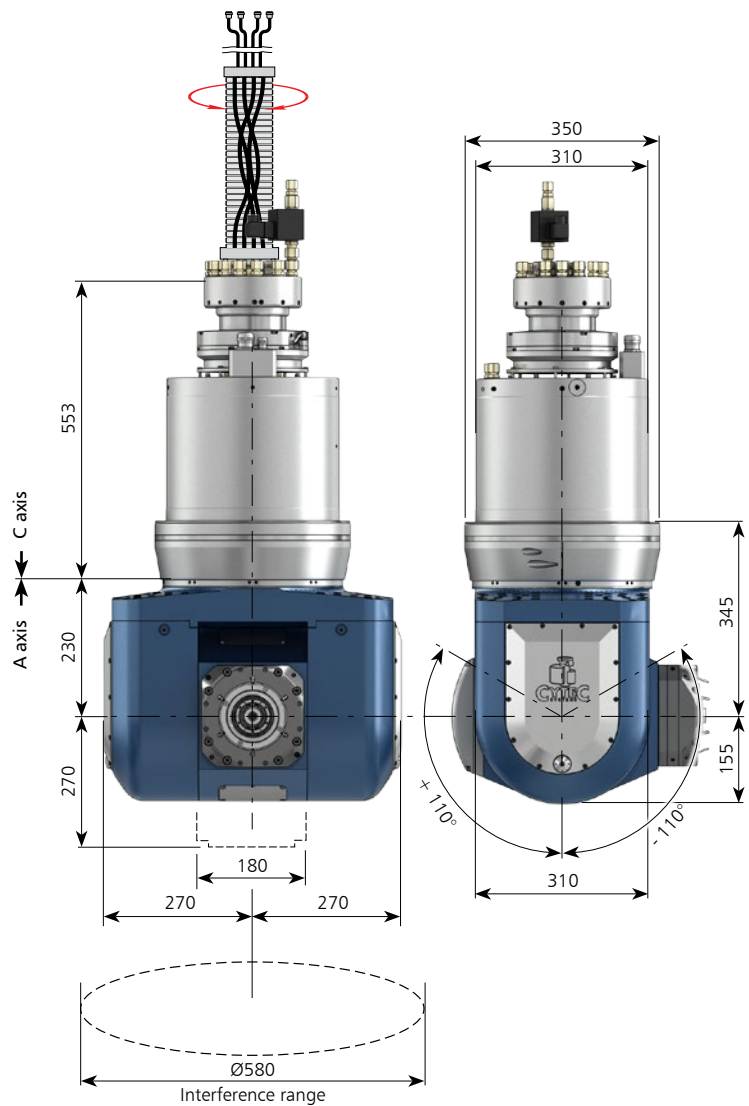



## Fork milling head Series M21

	A axis	C axis
Nom./max. torque [Nm]:	840/1,340	1,020/1,960
Nom. current [A]:	30	30
Clamping torque 60 bar [Nm]:	4,000	4,000
Swivel angle [°]:	±115	±360
Measuring system:	absolute	absolute
Positioning accuracy [″]:	±5	±2
Total weight appr. [kg]:	950	

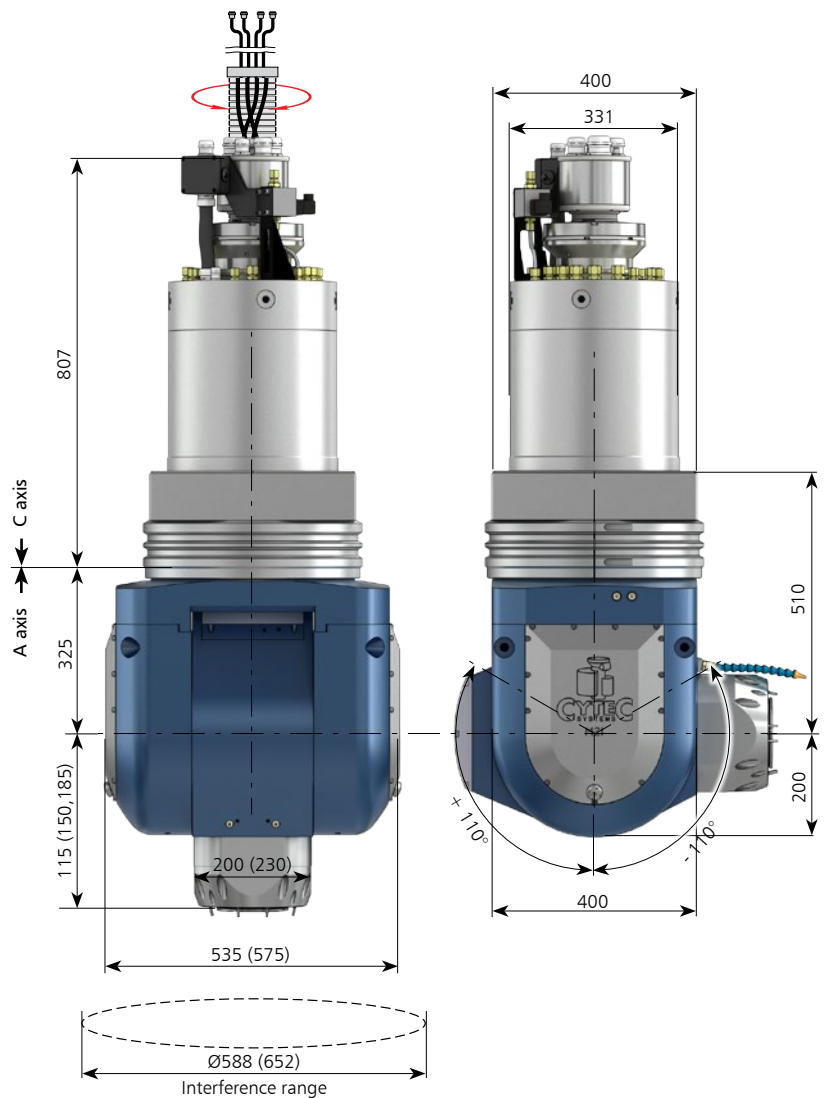

# Series

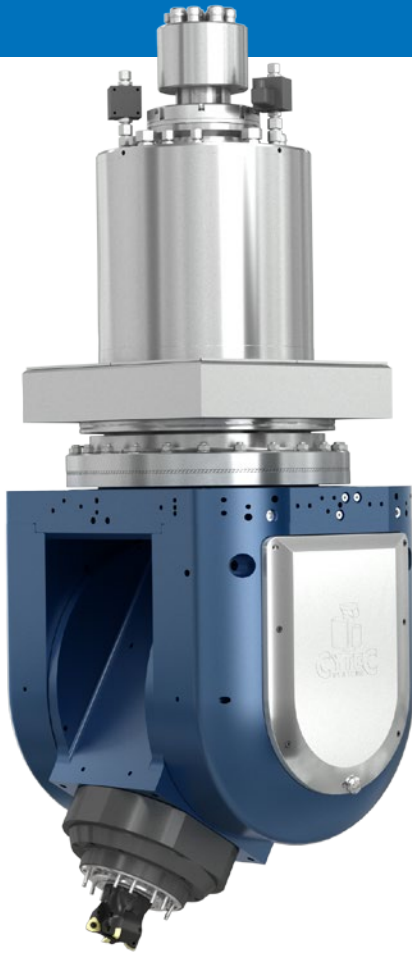

## Fork milling head Series G30

	A axis	C axis
Nom./max. torque [Nm]:	2,000/3,700	1,830/3,550
Speed max. [ $\text{min}^{-1}$ ]:	60	60
Max. acceleration [ $\text{min}^{-1}/\text{s}^2$ ]:	7	5
Nom. current [A]:	52	29
Clamping torque 60 bar [Nm]:	7,000	
Swivel angle [°]:	$\pm 110$	$\pm 360/\text{cont.}$
Measuring system:	absolute	absolute
Positioning accuracy [“]:	$\pm 2,5$	$\pm 2$
Total weight appr. [kg]:	1,200	

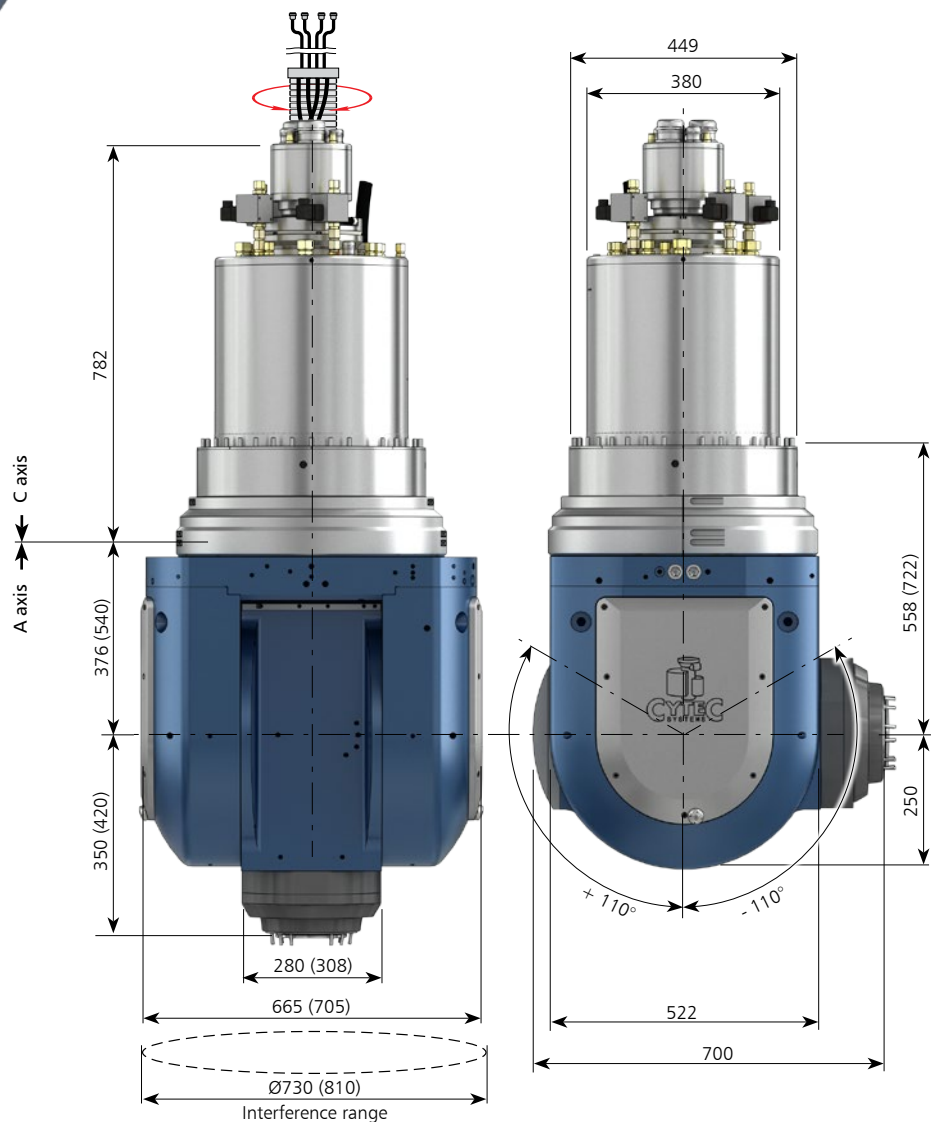



## Universal milling head Series M21 XL single axis

	A axis
Nom./max. torque [Nm]:	780/1,470
Nom. current [A]:	30
Clamping torque 50 bar [Nm]:	2,500
Swivel angle [°]:	±190
Measuring system:	absolute
Positioning accuracy [″]:	±2
Total weight appr. [kg]:	840

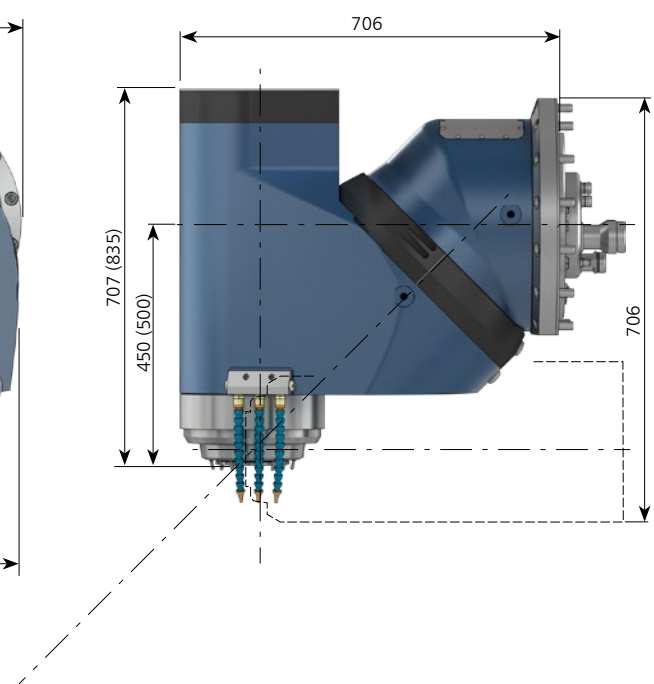
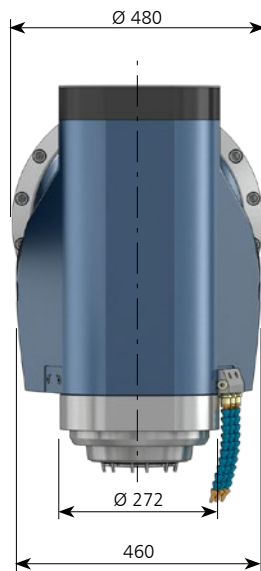

# Series

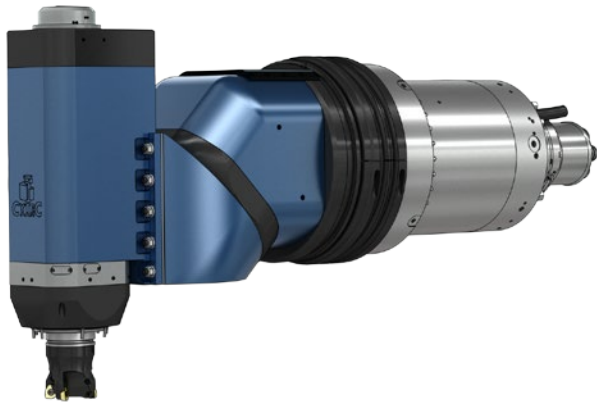

## Universal milling head Series M21 Double axis

	A axis	C axis
Nom./max. torque [Nm]:	552/1,058	1,022/1,985
Nom. current [A]:	14	30
Clamping torque 60 bar [Nm]:	2,000	4,000
Swivel angle [°]:	±180	±360
Measuring system:	absolute	absolute
Positioning accuracy [″]:	±2	±2
Total weight appr. [kg]:	870	

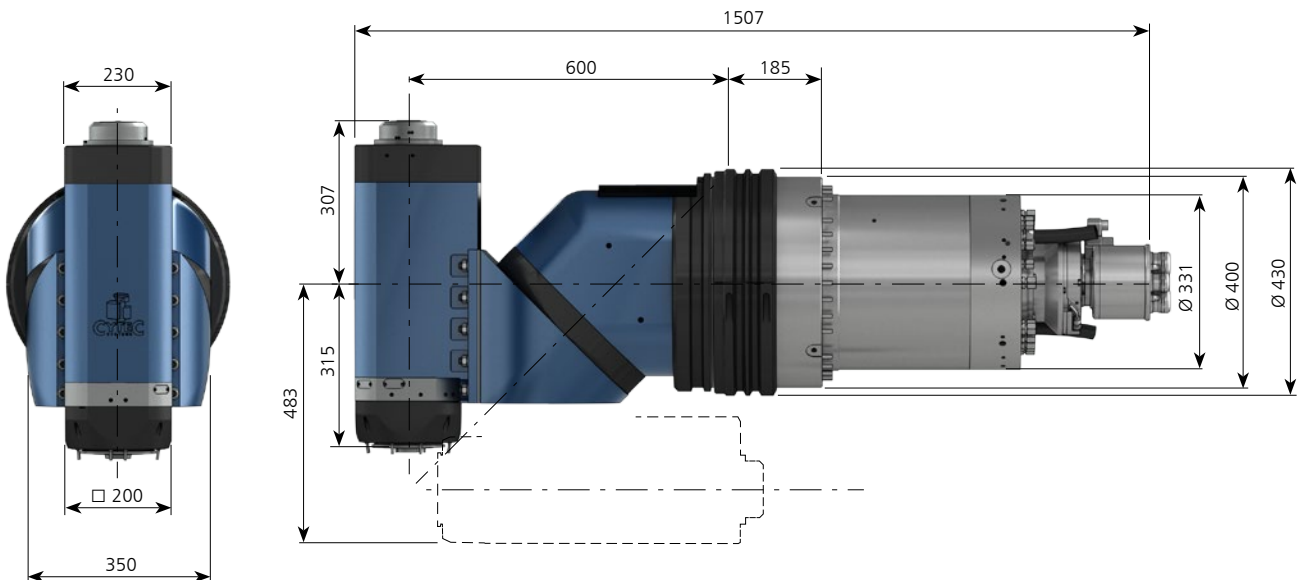



## Universal milling head Series M21 XL Double axis

	A axis	C axis
Nom./max. torque [Nm]:	780/1,470	1,020/1,960
Nom. current [A]:	30	30
Clamping torque 60 bar [Nm]:	2,500	4,000
Swivel angle [°]:	±190	±360
Measuring system:	absolute	absolute
Positioning accuracy [″]:	±2	±2
Total weight appr.[kg]:	960	

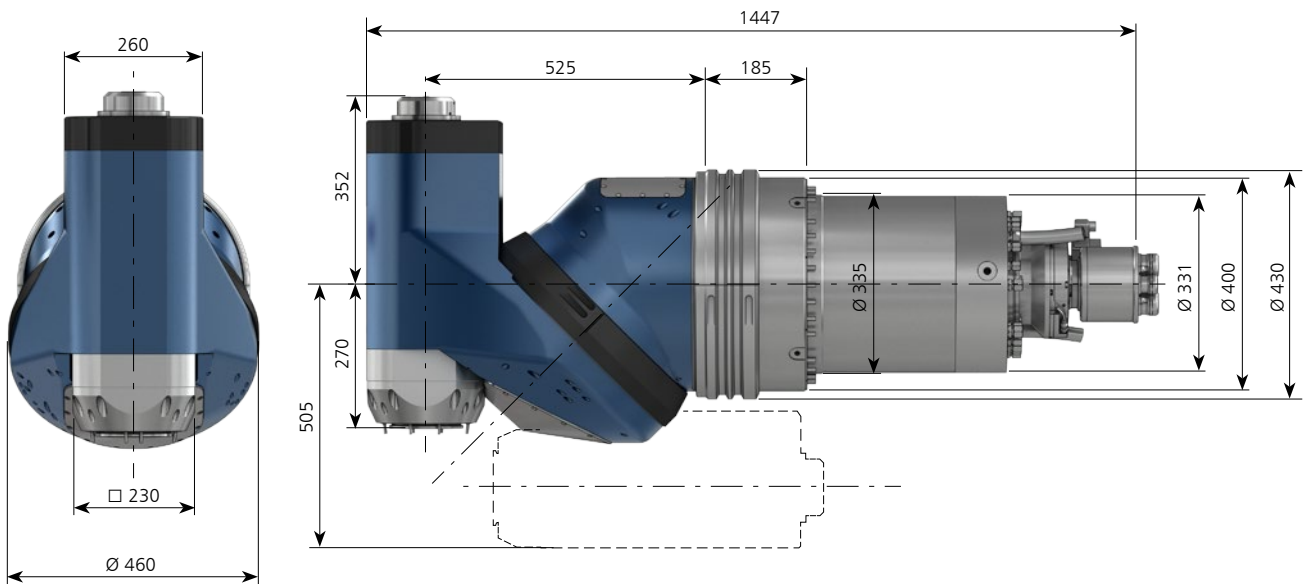

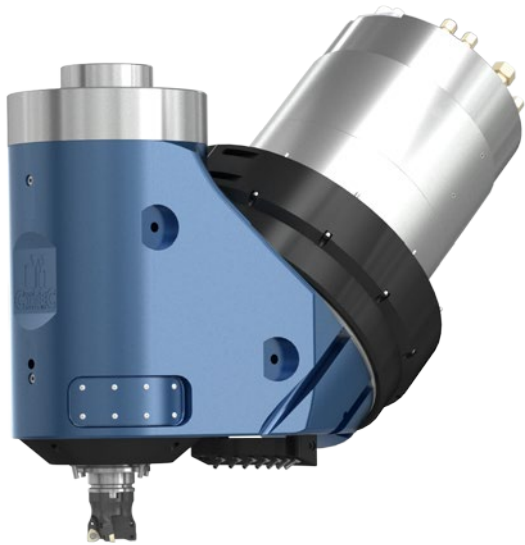

## Universal milling head Series M21 single axis

	A axis
Nom./max. torque [Nm]:	900/1,680
Nom. current [A]:	30
Clamping torque 50 bar [Nm]:	4,000
Swivel angle [°]:	±180
Measuring system:	absolute
Positioning accuracy [″]:	±2
Total weight appr. [kg]:	410

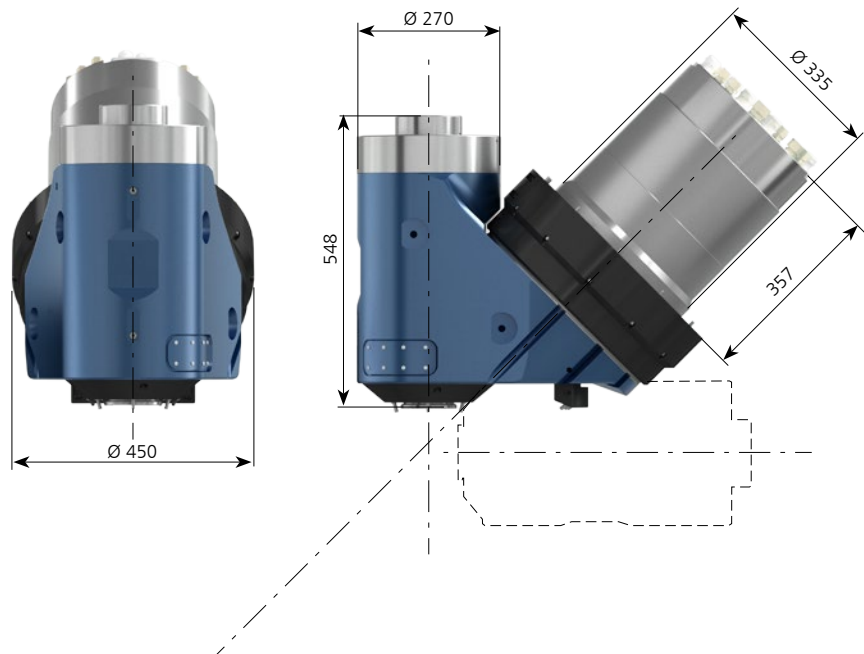





## Orthogonal milling head Series P12

	A axis	C axis
Nom./max. torque [Nm]:	433/817	490/820
Nom. current [A]:	14	30
Clamping torque 60 bar [Nm]:	1,400	2,500
Swivel angle [°]:	±120	±360
Measuring system:	absolute	absolute
Positioning accuracy [″]:	±2	±2
Total weight appr. [kg]:	470	

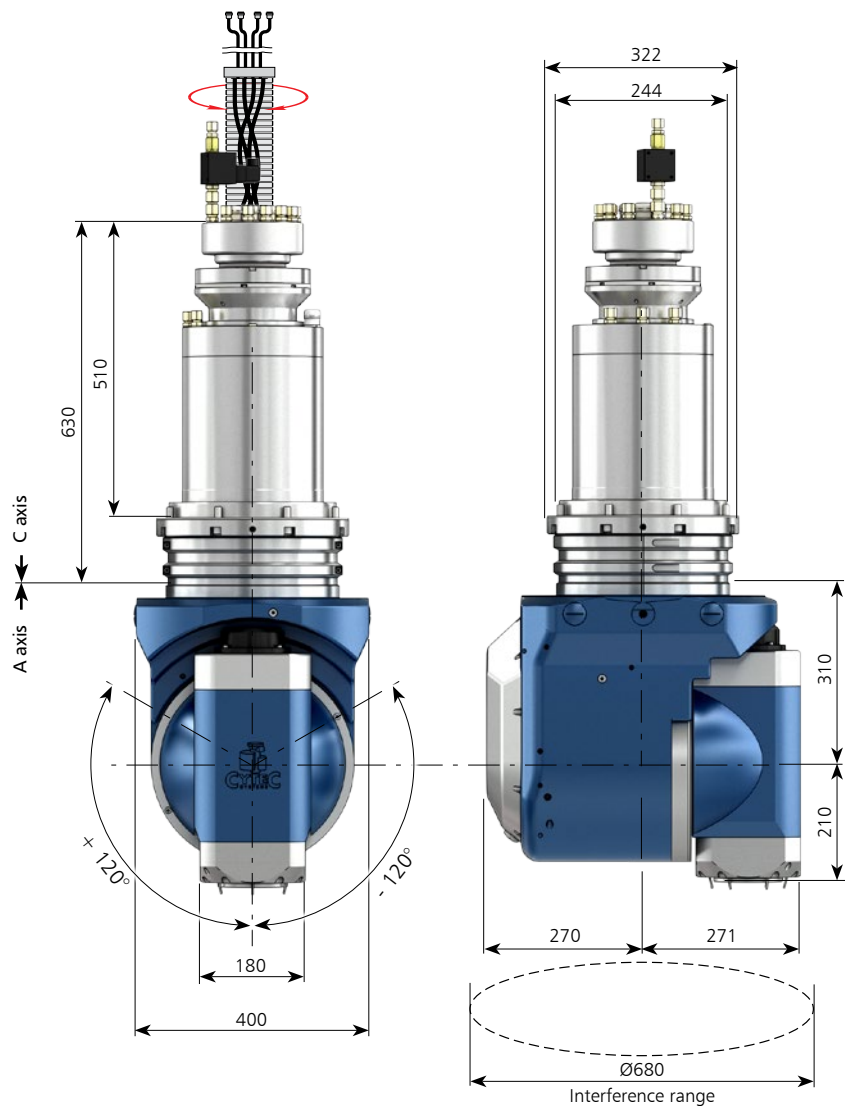

# Motor spindles

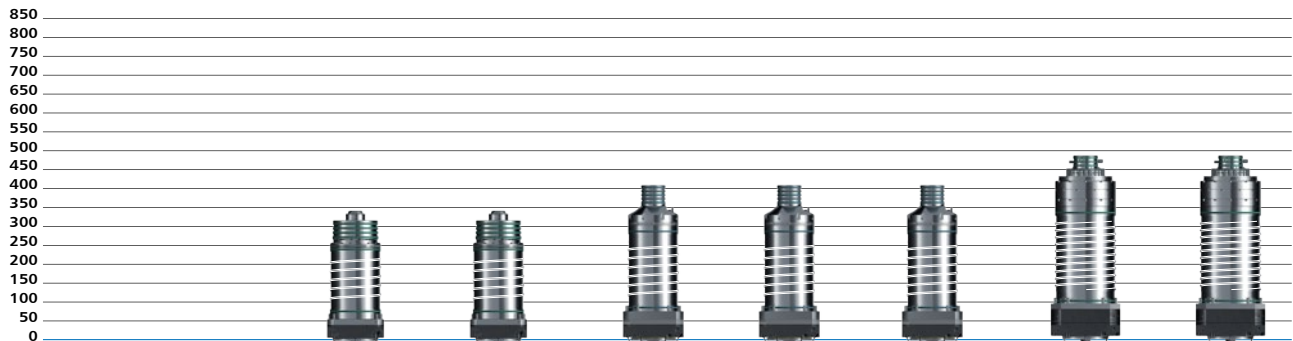

Milling Spindle Series	CS-13-135-A	CS-15-135-S	CS-18-135-S	CS-20-135-A	CS-26-135-S	CS-40-160-S	CS-45-160-S
For head series:	NANO		S8			S8 XL	
Power S1/S6 [kW]:	13/18	15/18,5	18/23	20/26	26/34	40/51	45/54
Nom. speed [min <sup>-1</sup> ]:	6,000	4,000	3,000	6,000	8,000	5,700	5,700
Torque S1/S6 [Nm]:	20/28	36/44	56/72	33/42	33/42	67/85	75/90
Speed max. [min <sup>-1</sup> ]:	24,000	10,000	18,000	24,000	15,000	24,000	18,000
Tool interface:	HSK-A63	HSK-A63	HSK-A63	HSK-A63	HSK-A63	HSK-A63	HSK-A63
Bearing lubrication:	Grease	Grease	Grease	Grease	Grease	Grease/Oil/air	Grease/Oil/air

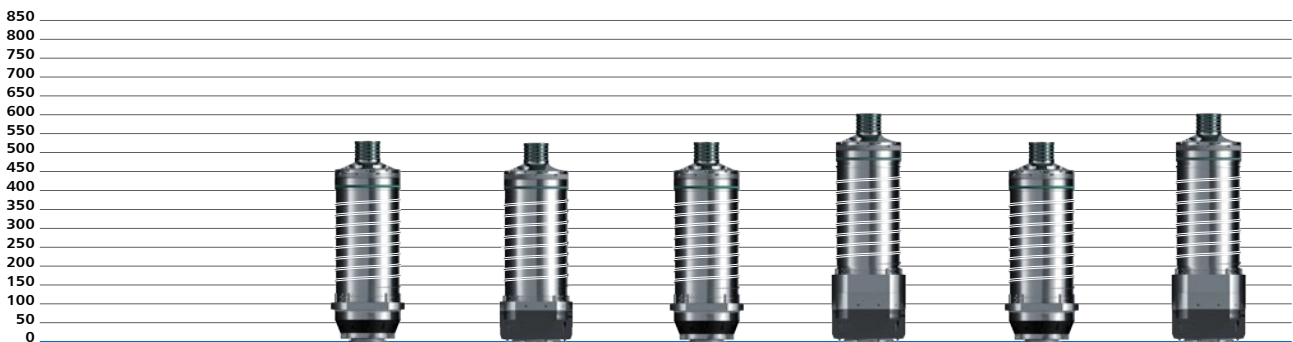

Milling Spindle Series:	CS-21-180-A	CS-27-180-S	CS-28-180-A	CS-34-180-S	CS-40-180-S	CS-42-180-S
For head series:	M21					
Power S1/S6 [kW]:	21/27	27/32	28/35	34/43	40/51	42/53
Nom, speed [min <sup>-1</sup> ]:	2,000	2,000	2,000	2,000	5,700	2,000
Torque S1/S6 [Nm]:	100/130	130/170	90/113	170/220	67/85	201/253
Speed max, [min <sup>-1</sup> ]:	18,000	12,000	20,000	12,000	24,000	12,000
Tool interface:	HSK-A63	HSK-A100	HSK-A63	HSK-A100	HSK-A63	HSK-A100
Bearing lubrication:	Grease	Grease	Grease/Oil/air	Grease	Grease	Grease

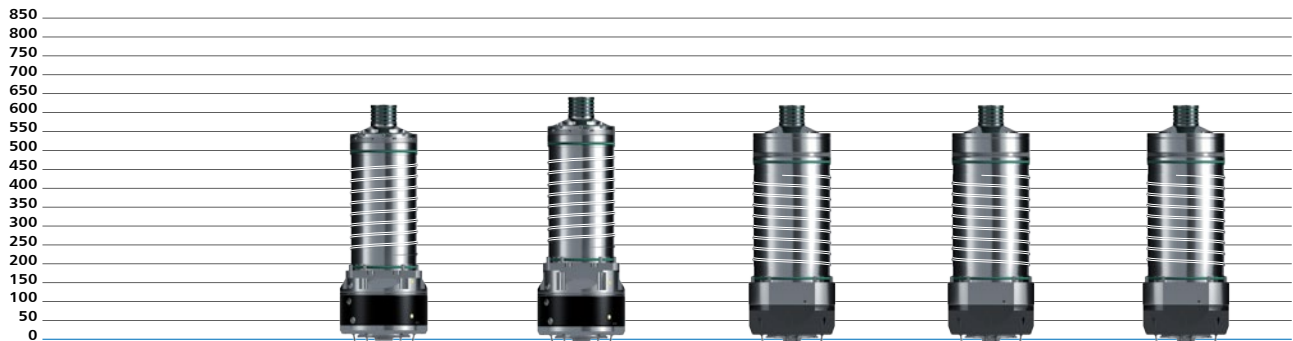

Milling Spindle Series	CST-27-180-S	CST-42-180-S	CS-40-200-S	CS-50-200-S	CS-70-200-S
For head series:	M21		M21 XL		
Power S1/S6 [kW]:	27/32	42/53	40/50	50/64	70/90
Nom. speed [min <sup>-1</sup> ]:	2,000	2,000	2,400	2,000	8,000
Torque S1/S6 [Nm]:	130/170	201/253	160/200	240/300	85/105
Speed max. [min <sup>-1</sup> ]:	12,000	12,000	15000	8000	22,000 (24,000)
Tool interface:	HSK-T63	HSK-T100	HSK-A100	HSK-A100	HSK-A63
Bearing lubrication:	Grease	Grease	Grease	Grease	Grease /Oil/air



Milling Spindle Series:	CS-40-238-S	CS-42-238-S	CST-42-238-S	CS-70-238-S	CS-75-260-A	CS-110-260-S
For head series:	G30					
Power S1/S6 [kW]:	40/48	42/55	42/53	70/90	75/94	110/138
Nom. speed [min <sup>-1</sup> ]:	1,350	1,000	1,000	8,000	1,600	1,600
Torque S1/S6 [Nm]:	280/340	400/525	400/506	85/105	484/620	700/824
Speed max. [min <sup>-1</sup> ]:	15.000	8.000	7.000	22.000	10.000	5.000
Tool interface:	HSK-A100	HSK-A100/ SK50/C8	HSK-A100	HSK-A63	HSK-A100/ SK50	HSK-A100
Bearing lubrication:	Grease	Grease	Grease	Grease	Grease	Grease

# CYTEC WORLD WIDE

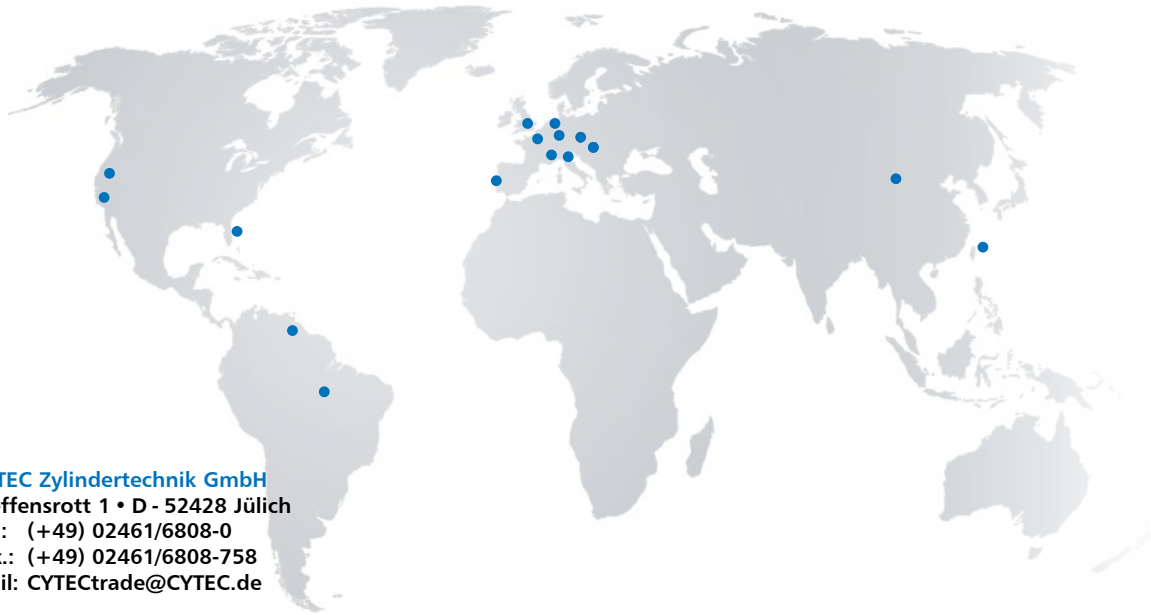

**1 CYTEC Zylindertechnik GmbH**  
Steffensrott 1 • D - 52428 Jülich  
Tel.: (+49) 02461/6808-0  
Fax.: (+49) 02461/6808-758  
Mail: CYTECtrade@CYTEC.de

**Sales department**  
CYTEC Zylindertechnik GmbH  
Carl-Zeiss-Str. 7  
D- 72124 Pliezhausen  
Tel.: (+49) 7127/811 880  
Fax.: (+49) 7127/811 885  
Mail: CYTECtrade@CYTEC.de

**Great Britain**  
CYTEC Systems UK Ltd.  
Unit H • 100 Shaw Road  
(Off Daltry Str.)  
GB- Oldham, OL1 4AB  
Tel.: (+44) 0161/678 70 90  
Mail: sales@CYTEC-uk.com  
Web: www.CYTECsystems-uk.com

**France**  
CYTEC Systems SARL  
Parc des Erables  
66 route de Sartrouville  
F- 78230 Le Pecq  
Tel.: (+33) 01 30 87 13 50  
Fax.: (+33) 01 30 87 13 51  
Mail: sales@CYTEC-fr.com  
Web: www.CYTEC-systems.fr

**Portugal**  
Nelson S. Bernardo Lda  
No 3, Loja 17  
Rua Fonte Cabeco d'El Rey  
2400-719 Leiria  
Tel.: (+351) 244 691 446  
Fax.: (+351) 244 695 166  
Mail: geral@nsb.pt  
Web: www.nsb.pt

**Italy**  
Emanuele Mascherpa S.p.A.  
Via Natale Battaglia, 39  
I- 20127 Milano  
Tel.: (+39) 02/280031  
Fax.: (+39) 02/2829945  
Mail: postmaster@mascherpa.it  
Web: www.mascherpa.it

**Czech Republic**  
KJ-tech  
S.R.O. Vilová 350460  
10 Liberec 10  
Tel.: (+420) 486141688  
Fax.: (+420) 485150130  
Web: www.kjtech.cz

**Switzerland**  
Geiger CYTEC Systems AG  
Steinhausstraße 40  
CH-3150 Schwarzenburg  
Tel.: (+41) 31 734 24 24  
Fax.: (+41) 31 734 24 25  
Mail: info@geigerCYTEC.com

**Hungary**  
Working KFT  
Budai Nagy Antal út 8  
HU-2400 Donauújváros  
Tel.: (+36) 25 513 300  
Mail: workingkft@invitel.hu

**USA**  
CYTEC Systems USA  
Tel.: (+1) 833-CYTECUS  
Mail: info@CYTEC-systems.com  
Web: www.CYTEC-systems.com

**East & Central USA**  
K&A Engineering, LLC  
Port Saint Lucie, FL 34986  
Tel.: (+1) 772.485.0822  
Mail: sales@kandaengineering.com  
Web: www.kandaengineering.com

**Western USA**  
CNC Matters  
2871 E via martens  
Anaheim, CA 92806  
Tel.: (+1) 855.426.2435  
Mail: cncmatters@gmail.com  
Web: www.cncmatters.com

**Central & South America**  
K&A Ingenieria CA  
Ofic 01-04.CC Quisqueya  
Calle Las Flores c/Rondon  
Cagua, Aragua - Venezuela  
Tel.: (+58) 414 395 6238  
Mail: ventas@kandaengineering.com  
Web: www.kandaengineering.com

**Brazil**  
Schütte Brasil  
Máquinas e Equipamentos  
Avenida Indianópolis  
3220 Indianópolis  
04062-003 São Paulo-SP  
Tel.: (+55) 11 5071-1808  
Mail: schutte.brasil@schuttebrasil.com

**China**  
CYTEC Systems China Ltd.  
301-2-10, Yilong International  
community 3, Changyuan,  
453400 Xixiang, Henan  
Tel.: (+86) 373/8821619  
Fax.: (+86) 373/8821619  
Web: www.CYTEC.cn

**Taiwan**  
Easymore Industrial Co., Ltd.  
No. 284, Daye Rd., Nantun Dist.  
Taichung City 40848, Taiwan  
Gyeonggi-do, Korea  
Tel.: (+886) 4 2310 0909  
Fax.: (+886) 4 2328 7433  
Mail: info@easymore.com.tw  
Web: www.easymore.com.tw

